

Water Pump Leak Inspection and Diagnostic Tips

Service Category Engine/Hybrid System

Section Cooling

Market USA

Toyota Supports
 ASE Certification 

Applicability

YEAR(S)	MODEL(S)	ADDITIONAL INFORMATION
2010 - 2021	4Runner, Tundra	
2019 - 2021	Avalon	
2018 - 2021	C-HR, Camry, Hilux	
2009 - 2021	Corolla	
2020 - 2021	Hiace	
2017 - 2021	Highlander	
2008 - 2011, 2013 - 2021	Land Cruiser	
2008 - 2021	Sequoia	
2017 - 2020	Sienna	
2010 - 2021	Tundra	

Introduction

This Service Bulletin provides updated non-electric water pump leak inspection and diagnostic tips for some 2008 – 2021 model year Toyota vehicles.

Water Pump Leak Inspection and Diagnostic Tips

Warranty Information

OP CODE	DESCRIPTION	TIME	OFF	T1	T2
N/A	Not Applicable to Warranty	–	–	–	–

APPLICABLE WARRANTY

- Warranty coverage is based on the failed component. Please refer to the Warranty Policy and Procedures Manual and the Powertrain Parts List for specific coverage.
- Warranty application is limited to occurrence of the specified condition described in this bulletin.

Warranty and Claim Submission: Warranty Policy 4.21.

- ANY leak repair to be performed under warranty requires photo documentation of the active leak.
- This documentation showing the cause of the defect MUST be created prior to the start of the repair and attached to the warranty claim.
- Photos MUST be clear and provide perspective image(s) that identify the vehicle identification number (VIN) and the affected component(s), and close-up image(s) that illustrate the defect or condition.
- For additional information regarding application and eligibility, please reference Warranty Policy 4.21.

Procedures

- [Water Pump Construction](#).....3
 - [Evaporation Port and Drain Plug](#).....3
 - [Mechanical Seal](#)4
- [Temporary and Active Leaks](#)5
- [Water Pump Replacement](#).....7
 - [Diagnostic Procedure](#).....7

Water Pump Leak Inspection and Diagnostic Tips

Water Pump Construction

Evaporation Port and Drain Plug

Figure 1. Typical Pump Assembly

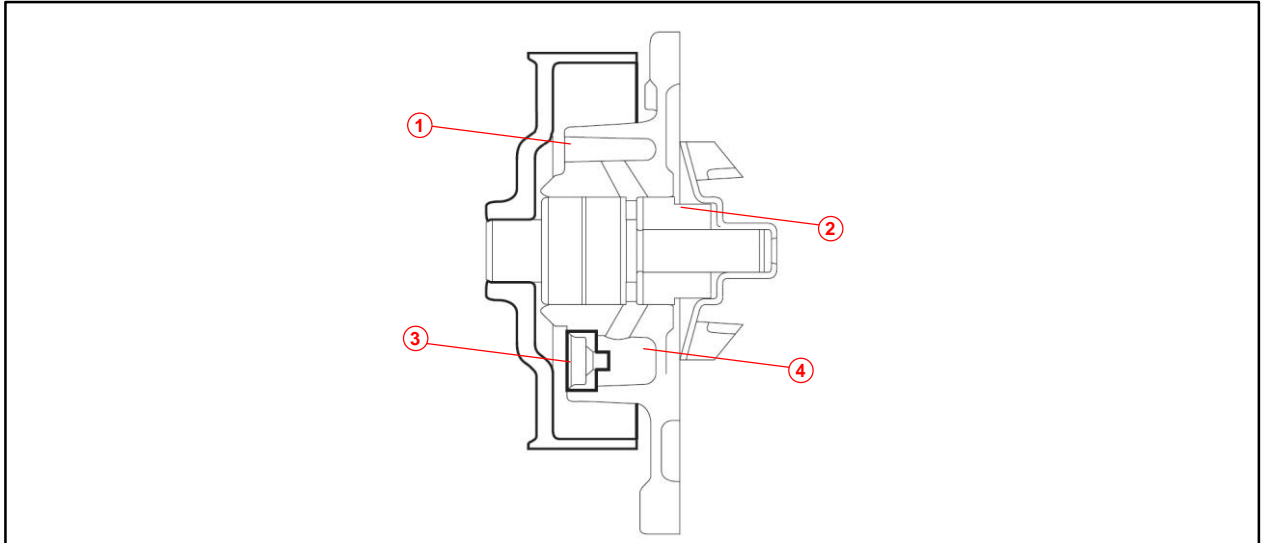

1	Evaporation Port
2	Mechanical Seal

3	Drain Pocket
4	Drain Plug

Water Pump Leak Inspection and Diagnostic Tips

Water Pump Construction (continued)

Mechanical Seal

The water pump shaft is sealed by a mechanical type seal.

Figure 2. Mechanical Seal

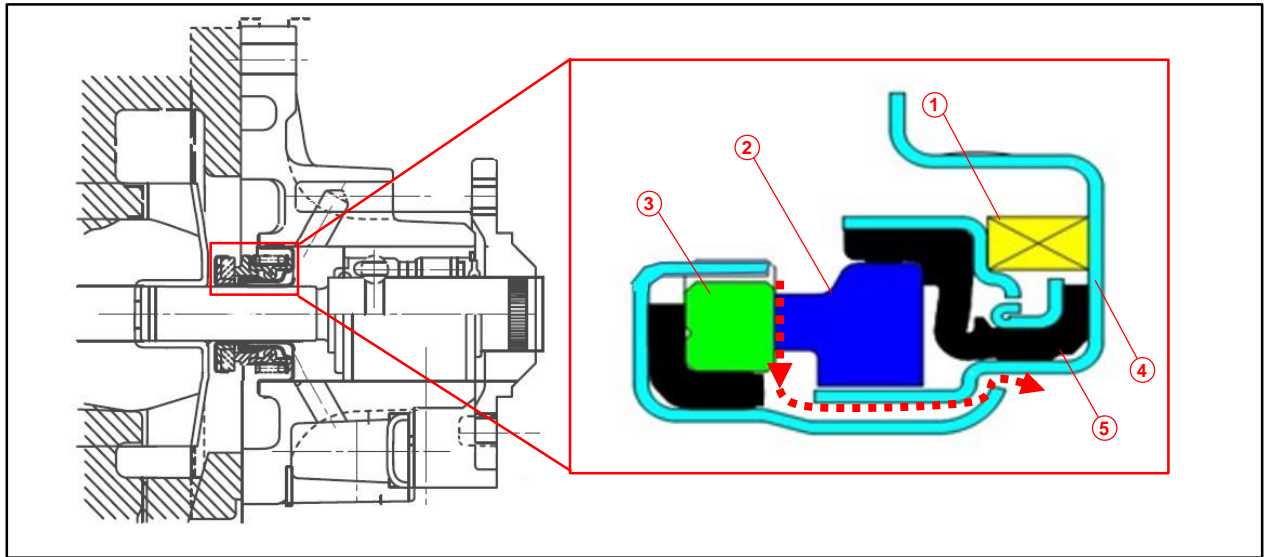

1	Spring – Applies Pressure to The Seal Ring To Ensure The Seal Ring And Mating Ring are in Constant Contact
2	Seal Ring – Stationary Sealing Member in the Water Pump Housing, Held in Place by the Cartridge
3	Mating Ring – Rotates With the Water Pump Shaft and Provides a Sealing Surface for the Seal Ring

4	Cartridge – Locates the Seal Ring and Bellows in the Water Pump Housing
5	Bellows – Seals the Cartridge and the Seal Ring

Water Pump Leak Inspection and Diagnostic Tips

Temporary and Active Leaks

Water pump replacement is NOT necessary for a temporary leak condition. The water pump should be replaced for an active leak condition. Examples of both conditions are shown below:

- As the water pump assembly rotates, a small amount of engine coolant is discharged to cool and lubricate the sliding surface of the mechanical seal and evaporates.

Figure 3. Temporary Leak – Dry Coolant Residue (Do Not Replace the Water Pump)

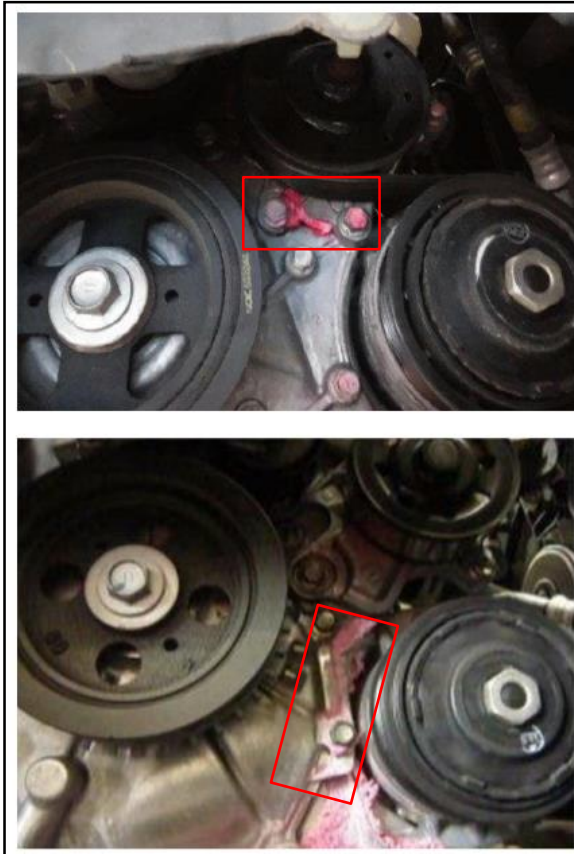

Figure 4. Active Leak Leak – Wet Coolant Residue/Drips (Replace the Water Pump)



Water Pump Leak Inspection and Diagnostic Tips

Temporary and Active Leaks (continued)

- If debris becomes lodged between the mating ring and seal ring, a small gap is formed. This allows coolant to bypass the mechanical seal, flow into the fluid catch pocket, and drain out of the weep hole. This condition is temporary and will no longer be present once the debris breaks up or works its way out of the seal.

Figure 5. Debris in Mechanical Seal

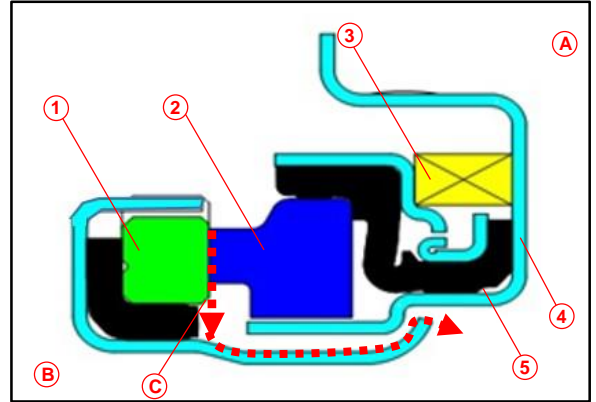

1	Mating Ring
2	Seal Ring
3	Spring
4	Cartridge
5	Bellows
A	Housing Side
B	Impeller Side
C	Gap Formed by Debris

Water Pump Leak Inspection and Diagnostic Tips

Water Pump Replacement

Diagnostic Procedure

1. Confirm if there are leaks from other areas of the cooling system not including from the water pump assembly.

NOTE

Refer to the applicable model and model year Repair Manual at *TIS – Cooling System – On-Vehicle Inspection – Inspect for Coolant Leak*.

Are ANY leaks present in the cooling system other than from the water pump?

- **YES** — Continue leak diagnosis using the applicable model and model year Repair Manual and correct any other cooling system leaks **BEFORE** proceeding.
 - **NO** — Continue to step 2.
2. Is the coolant level below the “low” indicator on the reservoir and does the water pump appear to be actively leaking?
 - **YES** — Replace the water pump. Refer to the applicable model and model year Repair Manual.
 - **NO** — Continue to step 3.
 3. Does the water pump pulley/bearing have excessive free play or does NOT turn smoothly?
 - **YES** — Replace the water pump. Refer to the applicable model and model year Repair Manual.
 - **NO** — Continue to step 4.

Water Pump Leak Inspection and Diagnostic Tips

Water Pump Replacement (continued)

Diagnostic Procedure (continued)

4. A paper towel should be used to determine if a leak is current or was temporary due to debris that has now cleared. Apply a dry paper towel to the coolant deposits around the water pump. If the paper towel remains dry, the leak was temporary and the water pump does NOT need to be replaced. If the paper towel becomes wet with coolant, the leak is active and the water pump should be replaced.

Figure 6.

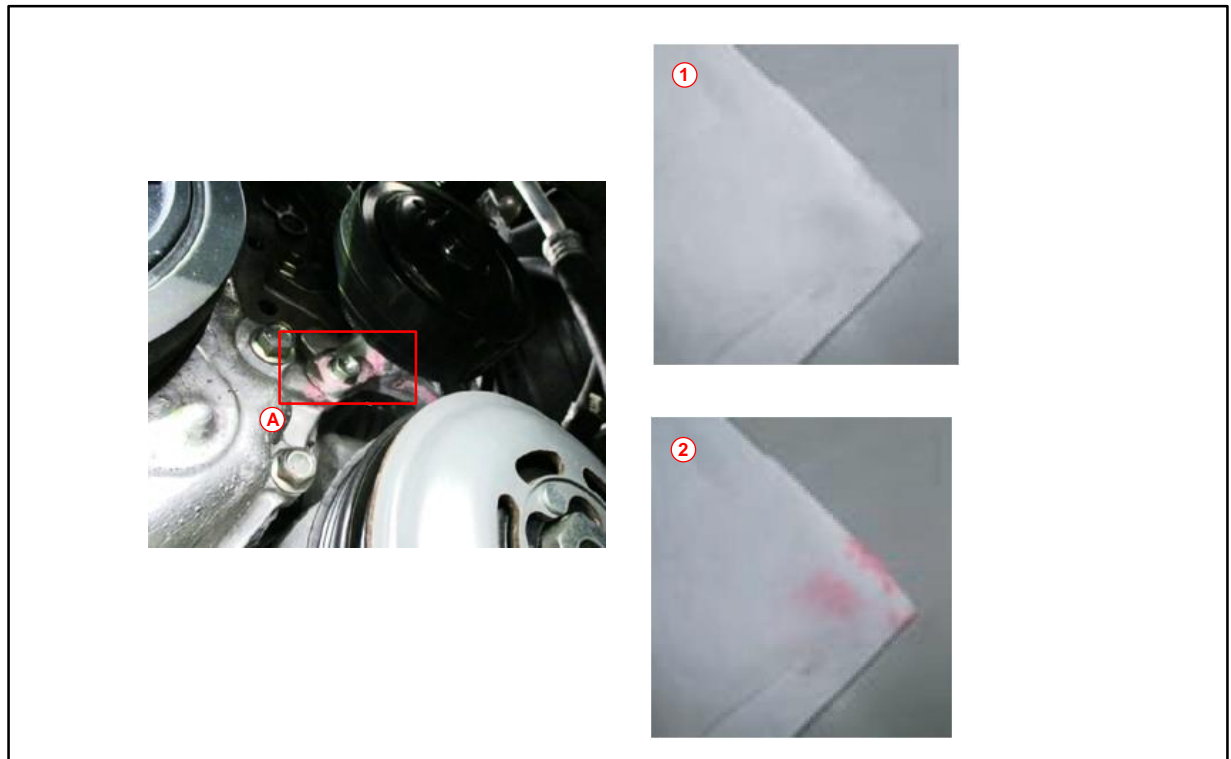

A	Apply a Dry Paper Towel to the Coolant Deposits
2	Wet Paper Towel

1	Dry Paper Towel
----------	-----------------

Is the paper towel wet with coolant?

- **YES** — Replace the water pump. Refer to the applicable model and model year Repair Manual.
- **NO** — No active leak is present. Confirm the coolant level in the reservoir is correct, adjust as necessary, and return the vehicle to the customer.

NOTE

Thoroughly clean ANY coolant residue from the engine and surrounding areas.