

| | | |
|------------|--------------|--|
| DTC | P0705 | Transmission Range Sensor Circuit Malfunction (PRNDL Input) |
|------------|--------------|--|

DESCRIPTION

The Park/Neutral Position (PNP) switch detects the shift lever position and sends signals to the ECM.

| DTC No. | DTC Detection Condition | Trouble Area |
|---------|--|--|
| P0705 | <p>When one of following conditions is met:</p> <p>(A) Any 2 or more of the following signals are ON simultaneously (2 trip detection logic)</p> <ul style="list-style-type: none"> • P input signal is ON • N input signal is ON • R input signal is ON • D input signal is ON • 2 input signal is ON • L input signal is ON <p>(B) Any 2 or more of the following signals are ON simultaneously (2 trip detection logic)</p> <ul style="list-style-type: none"> • NSW input signal is ON • R input signal is ON • D input signal is ON • 2 input signal is ON • L input signal is ON <p>(C) All of the signals are OFF simultaneously (2 trip detection logic)</p> <ul style="list-style-type: none"> • P input signal is OFF • N input signal is OFF • NSW input signal is OFF • R input signal is OFF • D input signal is OFF • 2 input signal is OFF • L input signal is OFF <p>(D) Both 1 and 2 are met (2 trip detection logic)</p> <p>1. Either of the following is met</p> <p>(a) NSW input signal is ON</p> <p>(b) P input signal is ON</p> <p>(c) N input signal is ON</p> <p>(d) R input signal is ON</p> <p>2. Either of the following is met</p> <p>(a) 3 input signal is ON</p> <p>(b) L input signal is ON</p> | <ul style="list-style-type: none"> • Open or short in park/neutral position switch circuit • Park/Neutral position switch • ECM |

AX**MONITOR DESCRIPTION**

These DTCs indicate a problem with the park/neutral position switch and the wire harness in the park/neutral position switch circuit.

The park/neutral position switch detects the shift lever position and sends a signal to the ECM.

For security, the park/neutral position switch detects the shift lever position so that the engine can be started only when the shift lever is on P or N.

The park/neutral position switch sends a signal to the ECM according to the shift lever position (R, D, 3, 2 or L).

The ECM determines that there is a problem with the switch or related parts if it receives more than 1 position signal simultaneously. The ECM will illuminate the MIL and store the DTC.

MONITOR STRATEGY

| | |
|-----------------------------|---|
| Related DTCs | P0705: Park/Neutral position switch/Verify switch input |
| Required sensors/Components | Park/Neutral position switch |
| Frequency of operation | Continuous |
| Duration | 2 seconds or 60 seconds |
| MIL operation | 2 driving cycles |

| | |
|-----------------------|------|
| Sequence of operation | None |
|-----------------------|------|

TYPICAL ENABLING CONDITIONS

| | |
|--|----------------|
| The monitor will run whenever this DTC is not present. | None |
| Ignition switch | ON |
| Battery voltage | 10.5 V or more |

AX

TYPICAL MALFUNCTION THRESHOLDS

Condition (A)

| | |
|---|-----------|
| Number of the following signal input at the same time | 2 or more |
| P switch | ON |
| N switch | ON |
| R switch | ON |
| D switch | ON |
| 2 switch | ON |
| L switch | ON |

Condition (B)

| | |
|---|-----------|
| Number of the following signal input at the same time | 2 or more |
| NSW switch | ON |
| R switch | ON |
| D switch | ON |
| 2 switch | ON |
| L switch | ON |

Condition (C)

| | |
|--|-----|
| When all of the following conditions are met | - |
| P switch | OFF |
| N switch | OFF |
| NSW switch | OFF |
| R switch | OFF |
| D switch | OFF |
| 2 switch | OFF |
| L switch | OFF |

Condition (D)

| | |
|--|----|
| When both conditions (a) and (b) are met | - |
| (a) When one of following condition is met | - |
| NSW switch | ON |
| P switch | ON |
| N switch | ON |
| R switch | ON |
| (b) When one of following condition is met | - |
| 3 switch | ON |
| L switch | ON |

COMPONENT OPERATING RANGE

| | |
|------------------------------|--|
| Park/Neutral position switch | Park/Neutral position switch sends only one signal to ECM. |
|------------------------------|--|

WIRING DIAGRAM

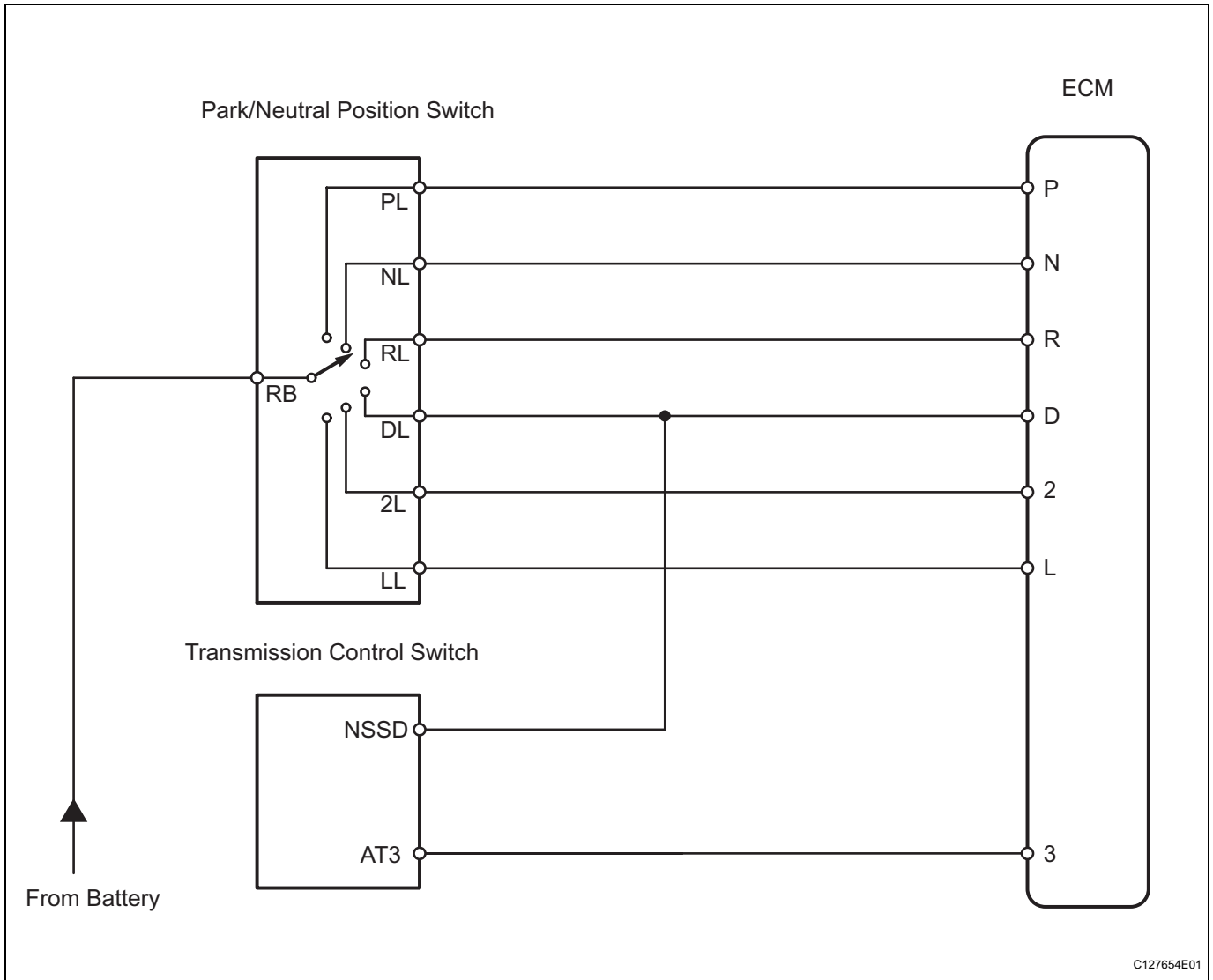

AX

C127654E01

INSPECTION PROCEDURE

HINT:

Using the intelligent tester's DATA LIST allows switch, sensor, actuator and other item values to be read without removing any parts. Reading the DATA LIST early in troubleshooting is one way to save time.

NOTICE:

In the table below, the values listed under "Normal Condition" are reference values. Do not depend solely on these reference values when deciding whether a part is faulty or not.

1. Warm up the engine.
2. Turn the ignition switch OFF.
3. Connect the intelligent tester to the CAN VIM. Then connect the CAN VIM to the DLC3.
4. Turn the ignition switch ON and turn the tester ON.
5. Enter the following menus: DIAGNOSIS / ENHANCED OBD II / DATA LIST.
6. Follow the instructions on the tester and read the DATA LIST.

| Item | Measurement Item/ Range (Display) | Normal Condition | Diagnostic Note |
|--------------|--------------------------------------|--|--|
| PNP SW (NSW) | PNP switch status/ ON or OFF | Shift lever is: On P or N: ON Not on P or N: OFF | When shift lever position displayed on intelligent tester differs from actual position, adjustment of PNP switch or shift cable may be incorrect |

AX

| Item | Measurement Item/ Range (Display) | Normal Condition | Diagnostic Note |
|---------|--------------------------------------|--|--|
| REVERSE | PNP switch status/ ON or OFF | Shift lever is: On R: ON Not on R: OFF | When shift lever position displayed on intelligent tester differs from actual position, adjustment of PNP switch or shift cable may be incorrect |
| PARKING | PNP switch status/ ON or OFF | Shift lever is: On P: ON Not on P: OFF | When shift lever position displayed on intelligent tester differs from actual position, adjustment of PNP switch or shift cable may be incorrect |
| NEUTRAL | PNP switch status/ ON or OFF | Shift lever is: On N: ON Not on N: OFF | When shift lever position displayed on intelligent tester differs from actual position, adjustment of PNP switch or shift cable may be incorrect |
| DRIVE | PNP switch status/ ON or OFF | Shift lever is: On D: ON Not on D: OFF | When shift lever position displayed on intelligent tester differs from actual position, adjustment of PNP switch or shift cable may be incorrect |
| 3RD | PNP switch status/ ON or OFF | Shift lever is: On 3: ON Not on 3: OFF | When shift lever position displayed on intelligent tester differs from actual position, adjustment of PNP switch or shift cable may be incorrect |
| 2ND | PNP switch status/ ON or OFF | Shift lever is: On 2: ON Not on 2: OFF | When shift lever position displayed on intelligent tester differs from actual position, adjustment of PNP switch or shift cable may be incorrect |
| LOW | PNP switch status/ ON or OFF | Shift lever is: On L: ON Not on L: OFF | When shift lever position displayed on intelligent tester differs from actual position, adjustment of PNP switch or shift cable may be incorrect |

1 CHECK WIRE HARNESS (PARK/NEUTRAL POSITION SWITCH - BATTERY)

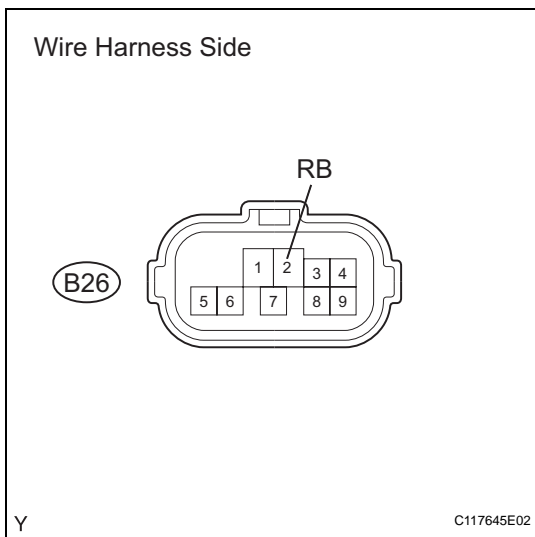

- (a) Disconnect the B26 park/neutral position switch connector.
- (b) Turn the ignition switch ON.
- (c) Measure the voltage.

Standard voltage

| Tester Connection | Specified Condition |
|----------------------|---------------------|
| 2 (RB) - Body ground | 10 to 14 V |

NG **CHECK POWER SOURCE OF ECM**

OK

2 INSPECT PARK/NEUTRAL POSITION SWITCH

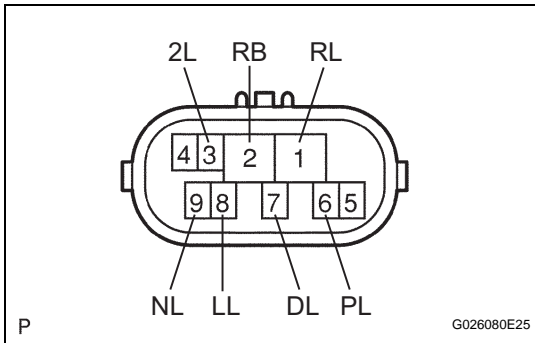

- (a) Disconnect the B26 park/neutral position switch connector.
- (b) Measure the resistance of the park/neutral position switch when the shift lever is moved to each position.

Standard resistance

| Tester Connection | Shift Lever Position | Specified Condition |
|-------------------|----------------------|---------------------|
| 6 (PL) - 2 (RB) | P | Below 1 Ω |
| 6 (PL) - 2 (RB) | Not on P | 10 kΩ or higher |
| 1 (RL) - 2 (RB) | R | Below 1 Ω |
| 1 (RL) - 2 (RB) | Not on R | 10 kΩ or higher |
| 9 (NL) - 2 (RB) | N | Below 1 Ω |
| 9 (NL) - 2 (RB) | Not on N | 10 kΩ or higher |
| 7 (DL) - 2 (RB) | D | Below 1 Ω |
| 7 (DL) - 2 (RB) | Not on D | 10 kΩ or higher |
| 3 (2L) - 2 (RB) | 2 | Below 1 Ω |
| 3 (2L) - 2 (RB) | Not on 2 | 10 kΩ or higher |
| 8 (LL) - 2 (RB) | L | Below 1 Ω |
| 8 (LL) - 2 (RB) | Not on L | 10 kΩ or higher |

NG → **REPLACE PARK/NEUTRAL POSITION SWITCH**

OK

3 CHECK WIRE HARNESS (ECM - BATTERY AND BODY GROUND)

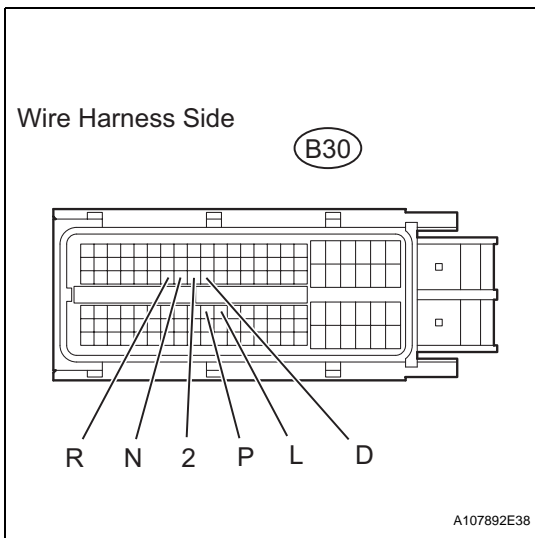

- (a) Disconnect the B30 ECM connector.
- (b) Turn the ignition switch ON.
- (c) Measure the voltage of the wire harness side connector.

Standard voltage

| Tester Connection | Shift Lever Position | Specified Condition |
|--------------------------|----------------------|---------------------|
| B30-73 (P) - Body ground | P | 10 to 14 V |
| B30-73 (P) - Body ground | Not on P | Below 1 V |
| B30-53 (R) - Body ground | R | 10 to 14 V* |
| B30-53 (R) - Body ground | Not on R | Below 1 V |
| B30-54 (N) - Body ground | N | 10 to 14 V |
| B30-54 (N) - Body ground | Not on N | Below 1 V |
| B30-56 (D) - Body ground | D or 3 | 10 to 14 V |
| B30-56 (D) - Body ground | Not on D or 3 | Below 1 V |
| B30-55 (2) - Body ground | 2 | 10 to 14 V |

AX

| Tester Connection | Shift Lever Position | Specified Condition |
|--------------------------|----------------------|---------------------|
| B30-55 (2) - Body ground | Not on 2 | Below 1 V |
| B30-74 (L) - Body ground | L | 10 to 14 V |
| B30-74 (L) - Body ground | Not on L | Below 1 V |

HINT:

*: The voltage will drop slightly due to the illumination of the back-up light.

NG REPAIR OR REPLACE HARNESS AND CONNECTOR

OK

4 CHECK WIRE HARNESS (PARK/NEUTRAL POSITION SWITCH - TRANSMISSION CONTROL SWITCH)

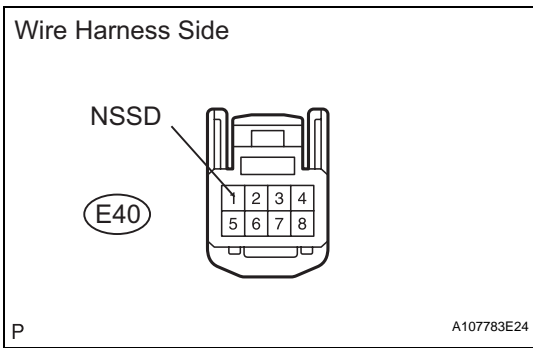

- (a) Disconnect the E40 switch connector.
- (b) Turn the ignition switch ON.
- (c) Measure the voltage when the shift lever is moved to each position.

Standard voltage

| Tester Connection | Shift Lever Position | Specified Condition |
|------------------------|----------------------|---------------------|
| 1 (NSSD) - Body ground | D and 3 | 10 to 14 V |
| 1 (NSSD) - Body ground | Not on D and 3 | Below 1 V |

NG REPAIR OR REPLACE HARNESS AND CONNECTOR

OK

5 INSPECT TRANSMISSION CONTROL SWITCH

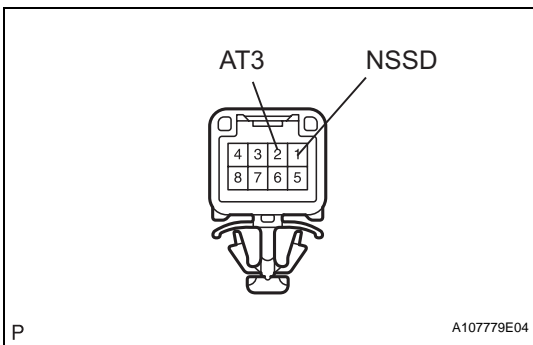

- (a) Disconnect the E40 switch connector.
- (b) Measure the resistance of the switch when the shift lever is moved to each position.

Standard resistance

| Tester Connection | Shift Lever Position | Specified Condition |
|--------------------|----------------------|---------------------|
| 1 (NSSD) - 2 (AT3) | D | 10 kΩ or higher |
| 1 (NSSD) - 2 (AT3) | 3 | Below 1 Ω |

NG REPLACE TRANSMISSION CONTROL SWITCH

OK

6 CHECK WIRE HARNESS (TRANSMISSION CONTROL SWITCH - BATTERY AND BODY GROUND)

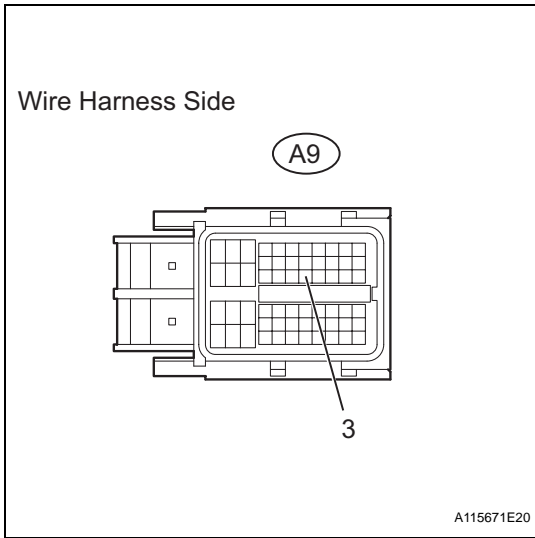

- (a) Disconnect the A9 ECM connector.
- (b) Turn the ignition switch ON.
- (c) Measure the voltage of the wire harness side connector.

Standard voltage

| Tester Connection | Shift Lever Position | Specified Condition |
|-------------------------|----------------------|---------------------|
| A9-26 (3) - Body ground | 3 | 10 to 14 V |
| A9-26 (3) - Body ground | Not on 3 | Below 1 V |

HINT:

*: The voltage will drop slightly due to the illumination of the back-up light.

NG → **REPAIR OR REPLACE HARNESS AND CONNECTOR**

OK

REPLACE ECM