

Electronically Controlled Transmission and A/T Indicator <2AZ-FE , Except TMC Made>

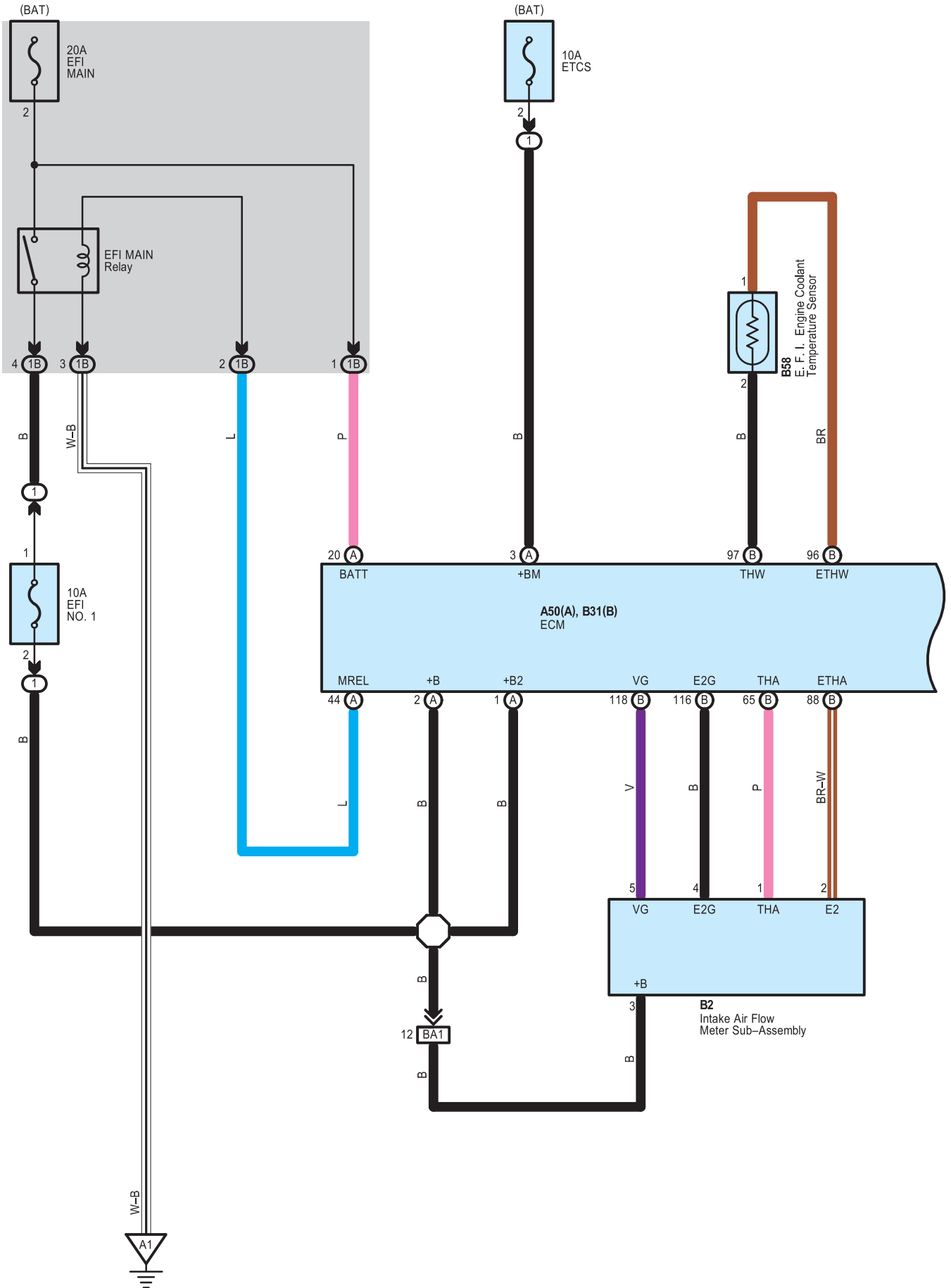

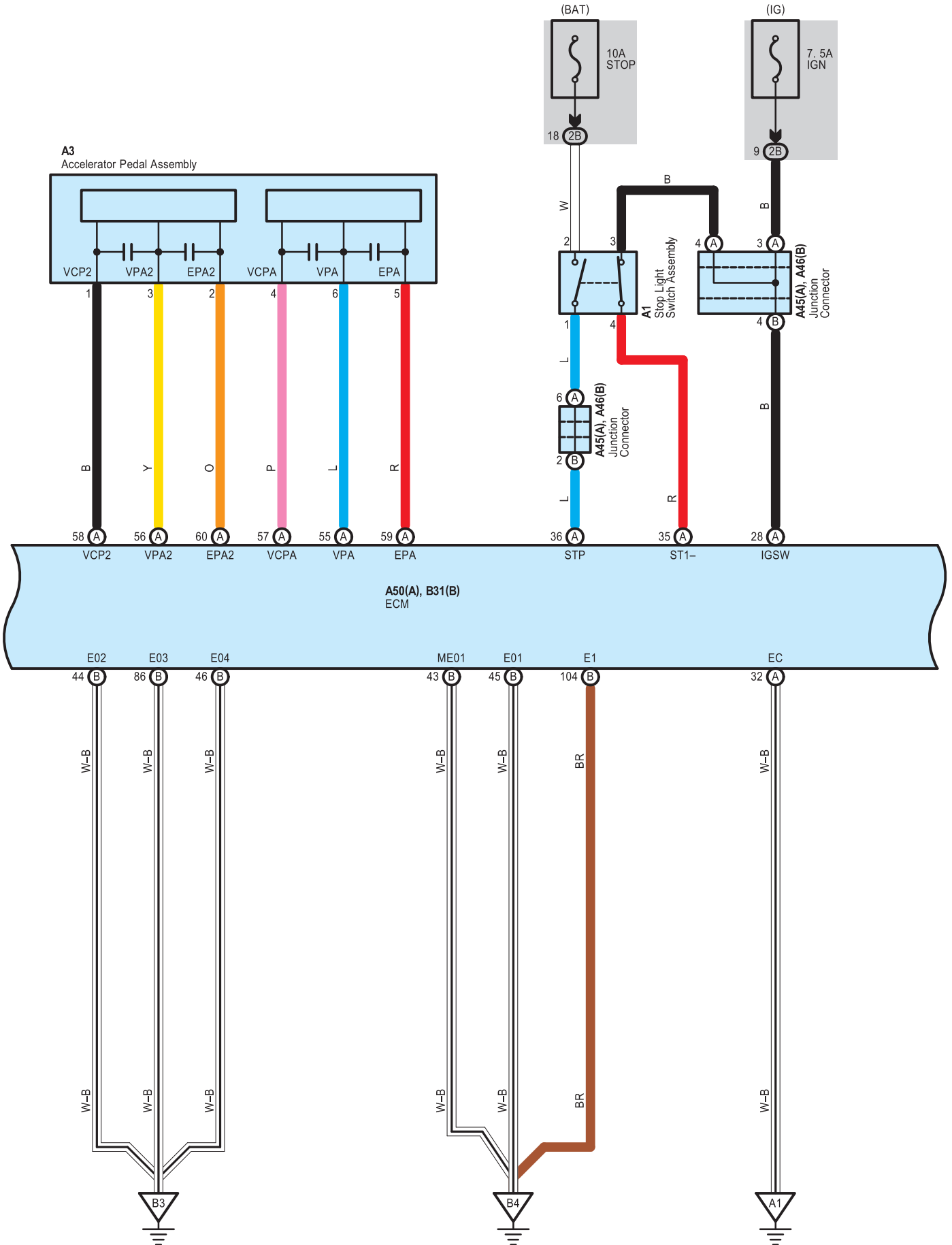

* 1 : Shielded

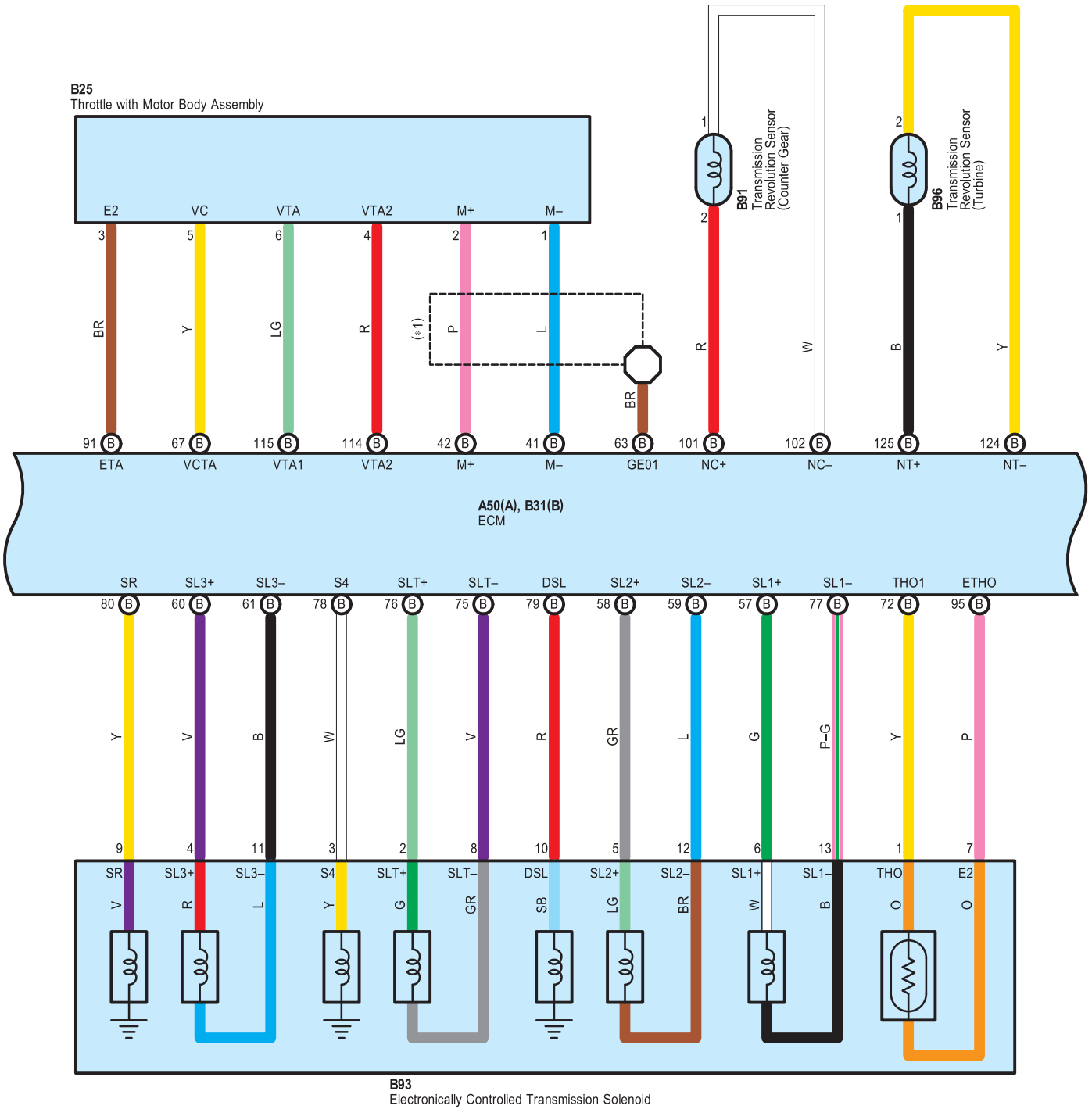

Electronically Controlled Transmission and A/T Indicator <2AZ-FE , Except TMC Made>

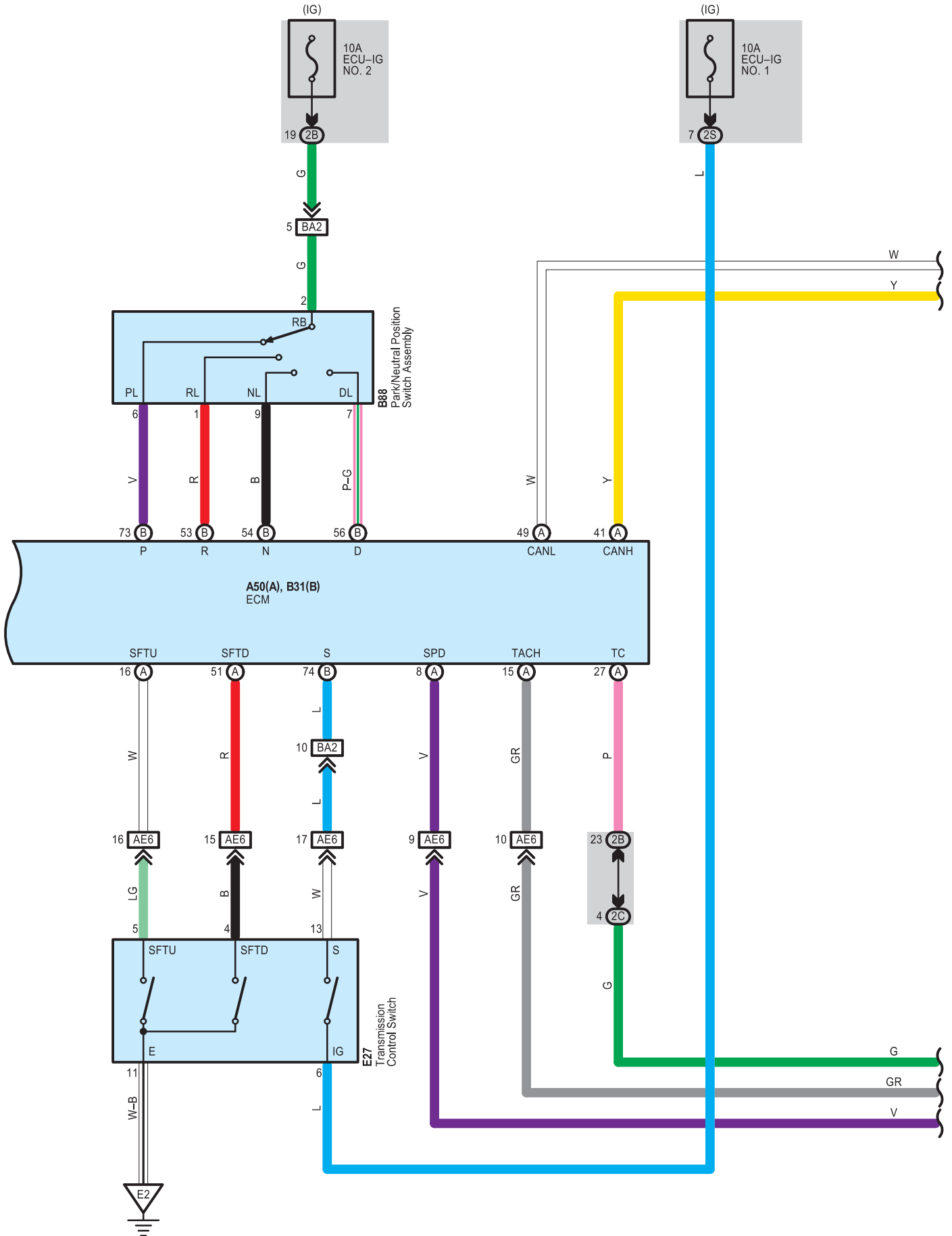

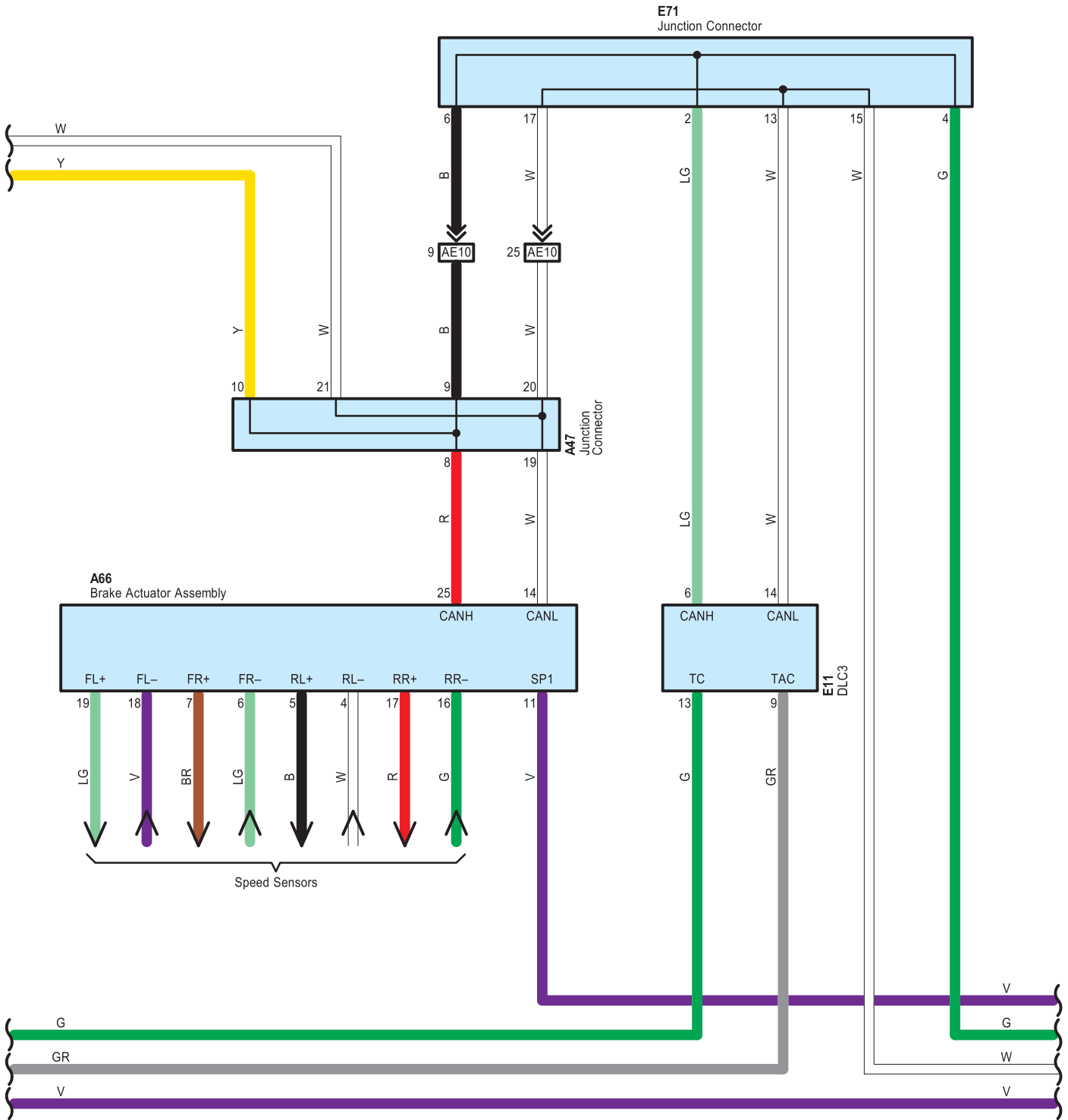

Electronically Controlled Transmission and A/T Indicator <2AZ-FE , Except TMC Made>

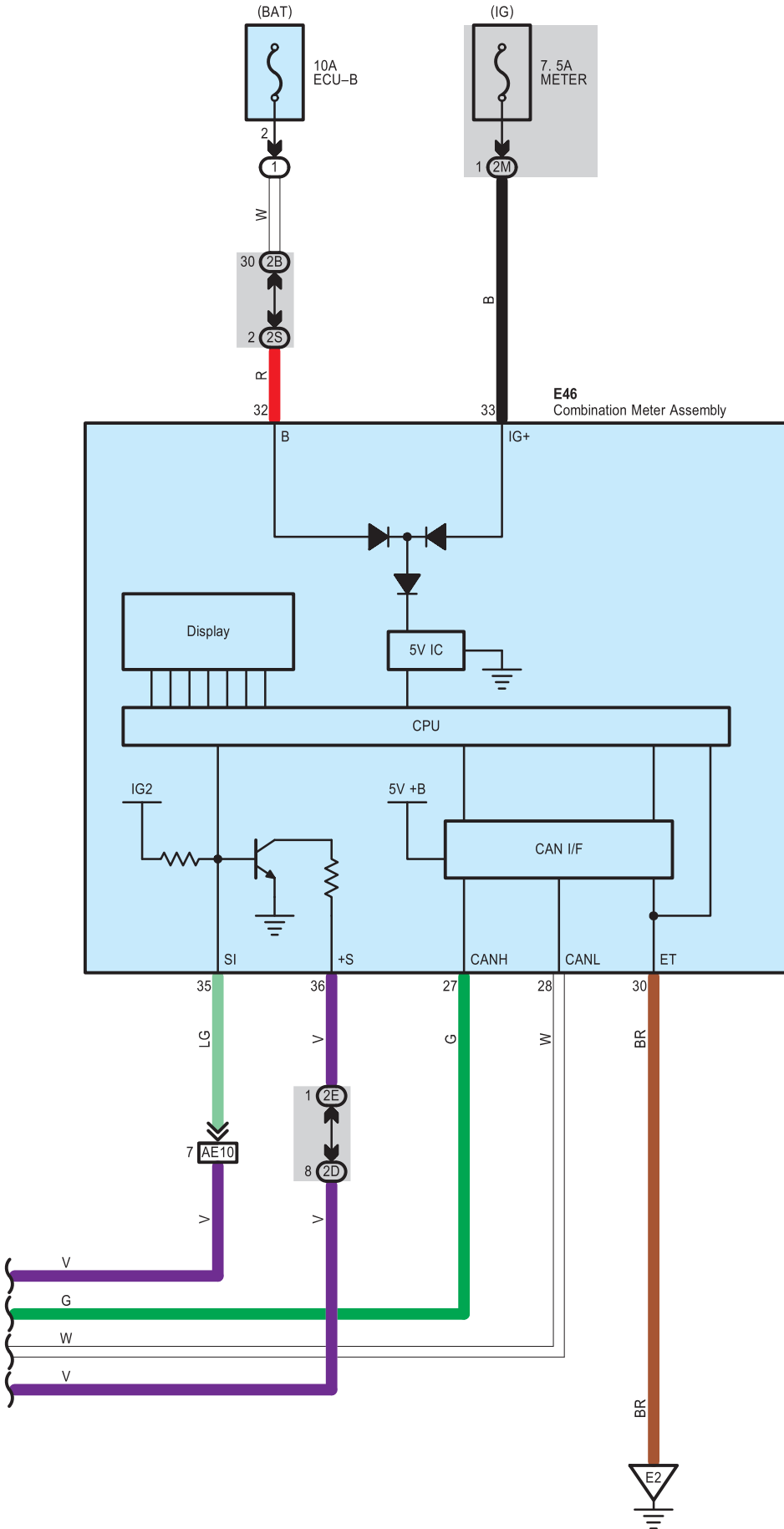

Electronically Controlled Transmission and A/T Indicator <2AZ-FE , Except TMC Made>

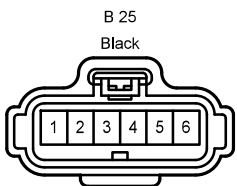
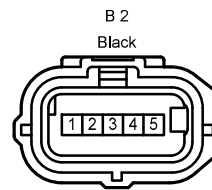
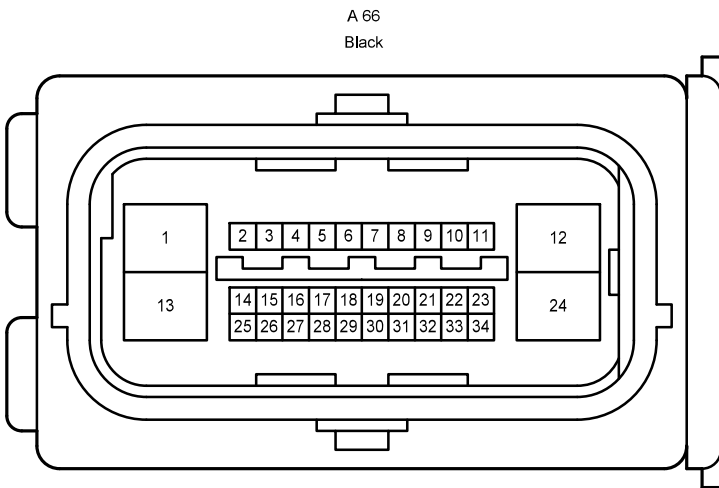
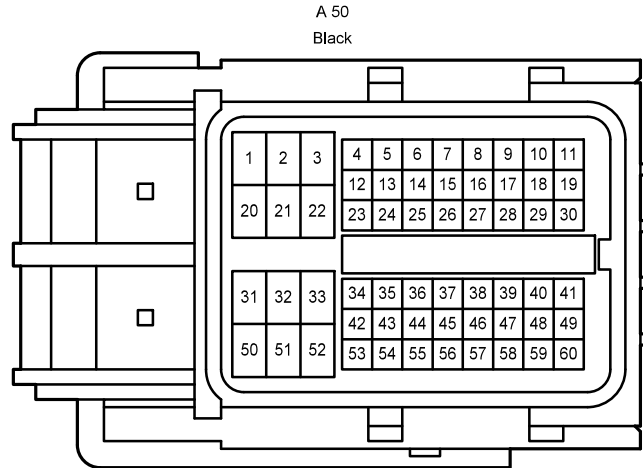
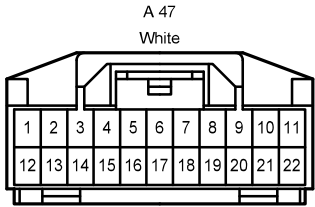
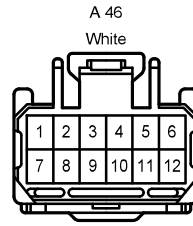
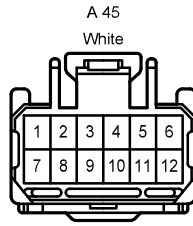
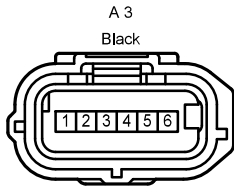
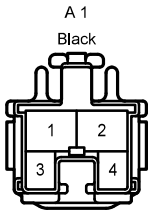

Electronically Controlled Transmission and A/T Indicator <2AZ-FE , Except TMC Made>

B 31
Black

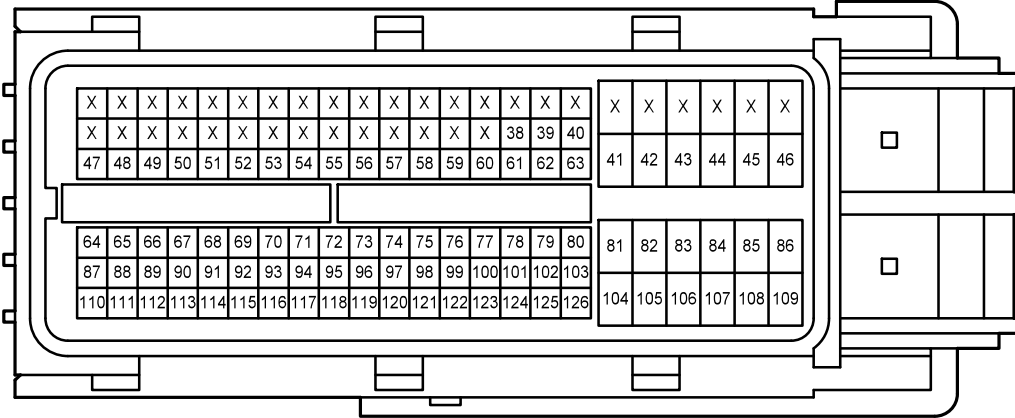

B 58
Gray



B 88
Gray

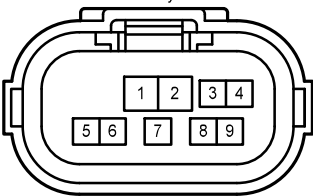

B 91
Black

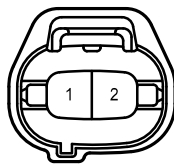

B 93
Gray

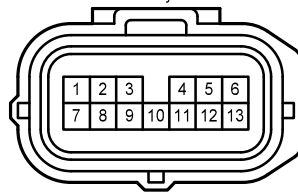

B 96
Black

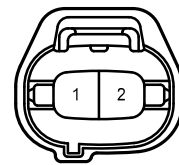

E 11
White

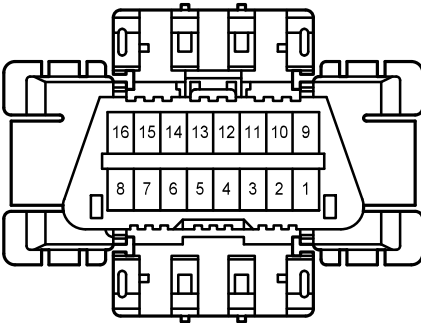

E 27
White

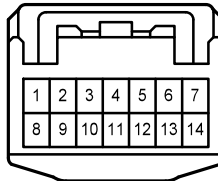

E 46
White

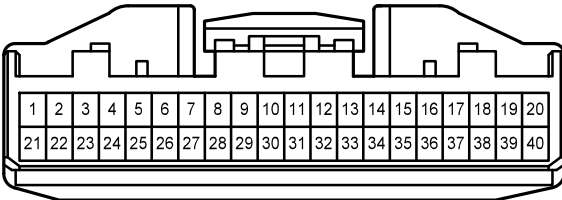

E 71
White

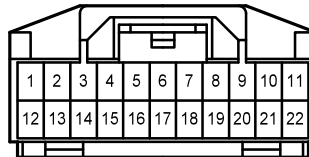

1B
White

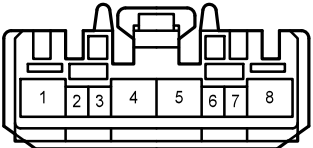

2B
White

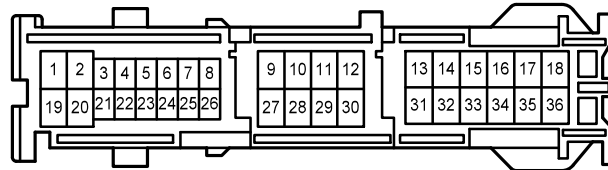

Electronically Controlled Transmission and A/T Indicator <2AZ-FE , Except TMC Made>

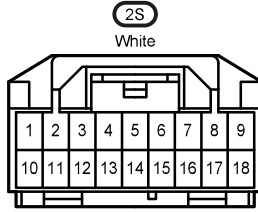
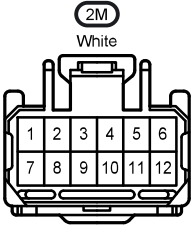
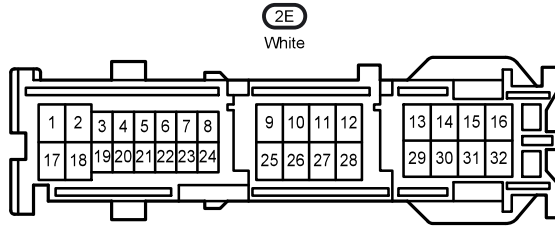
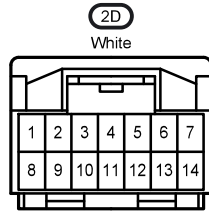
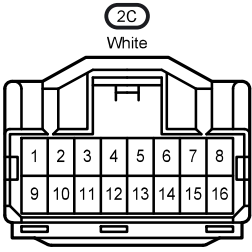

AE6
Gray

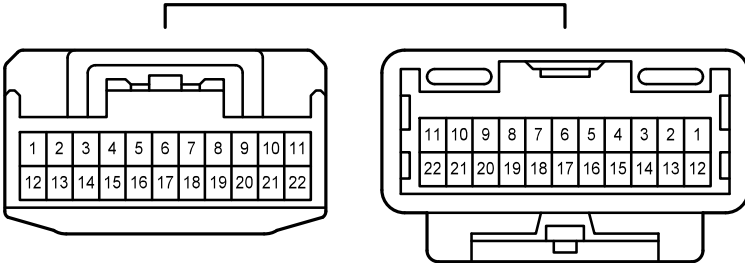

AE10
Gray

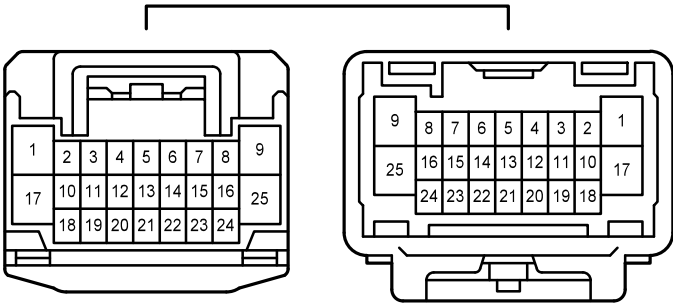

BA1
White

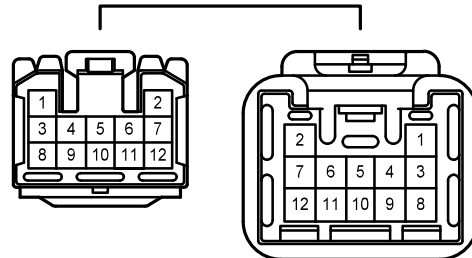

BA2
White

