

## ■ 2AR-FE ENGINE

### 1. General

The 2AR-FE engine is an in-line, 4-cylinder, 2.5-liter, 16-valve DOHC engine. This engine uses the Dual VVT-i (Variable Valve Timing-intelligent) system, DIS (Direct Ignition System), ACIS (Acoustic Control Induction System) and ETCS-i (Electronic Throttle Control System-intelligent). It has been developed to achieve high performance, quietness, fuel economy and clean emission.

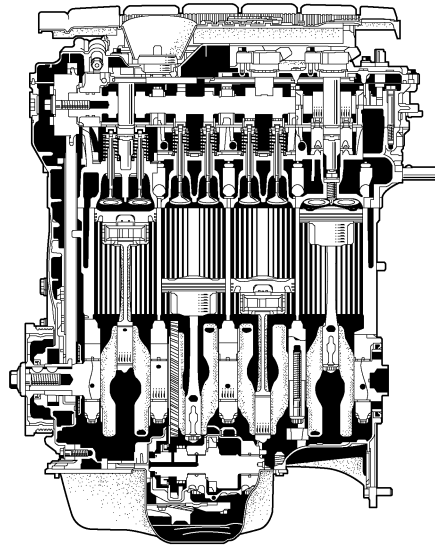

10SEG01Y

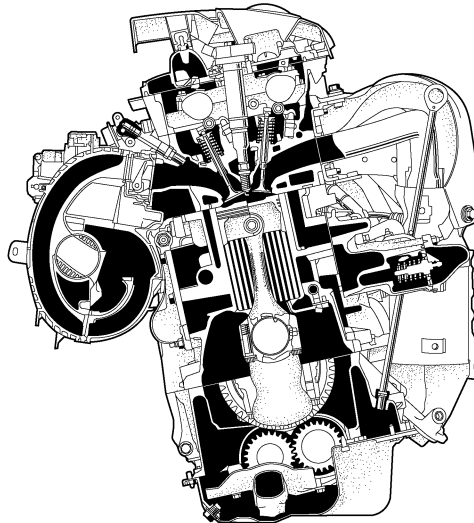

10SEG02Y

## ► Engine Specifications ◀

Model			'09 RAV 4	'08 RAV4
Engine			2AR-FE	2AZ-FE
No. of Cyls. & Arrangement			4-cylinder, In-line	←
Valve Mechanism			16-valve DOHC, Chain Drive (with Dual VVT-i)	16-valve DOHC, Chain Drive (with VVT-i)
Combustion Chamber			Pentroof Type	←
Manifolds			Cross-flow	←
Fuel System			SFI	←
Ignition System			DIS	←
Displacement			2494 cm <sup>3</sup> (152.2 cu.in.)	2362 cm <sup>3</sup> (144.1 cu. in.)
Bore × Stroke			90.0 × 98.0 mm (3.54 × 3.86 in.)	88.5 × 96.0 mm (3.48 × 3.78 in.)
Compression Ratio			10.4 : 1	9.8 : 1
Max. Output* <sup>1</sup>		(SAE-NET)	134 kW @ 6000 rpm (180 HP @ 6000 rpm)	124 kW @ 6000 rpm (166 HP @ 6000 rpm)
Max. Torque* <sup>1</sup>		(SAE-NET)	235 N·m @ 4100 rpm (173 ft·lbf @ 4100 rpm)	224 N·m @ 4000 rpm (165 ft·lbf @ 4000 rpm)
Valve Timing	Intake	Open	3° – 53° BTDC	3° – 43° BTDC
		Closed	61° – 11° ABDC	65° – 25° ABDC
	Exhaust	Open	60° – 20° BBDC	45° BBDC
		Closed	4° – 44° ATDC	3° ATDC
Firing Order			1 – 3 – 4 – 2	←
Research Octane Number			91 or higher	←
Octane Rating			87 or higher	←
Tailpipe Emission Regulation			ULEV-II, SFTP	←
Evaporative Emission Regulation			LEV-II, ORVR	←
Engine Service Mass (Reference) * <sup>2</sup>			147 kg (324.0 lb)	138 kg (304.2 lb)

\*1: Maximum output and torque rating is determined by revised SAE J1349 standard.

\*2: Weight shows the figure with oil and engine coolant fully filled.

► Performance Curve ◀

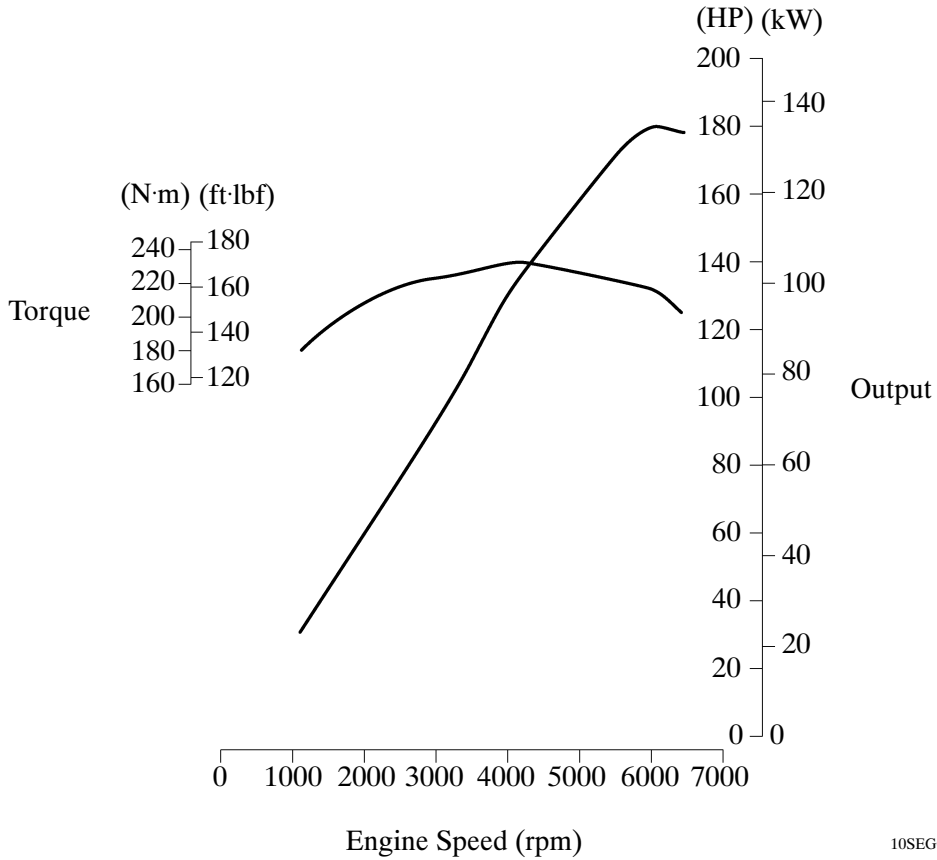

10SEG03Y

► Valve Timing ◀

◀ : Intake Valve Opening Angle  
▶ : Exhaust Valve Opening Angle

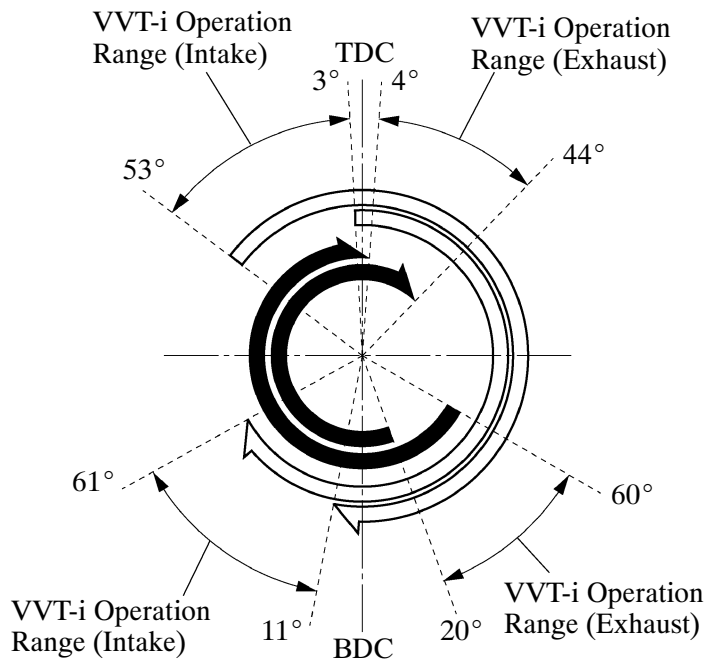

10SEG04Y

## 2. Features of 2AR-FE Engine

The 2AR-FE engine has achieved the following performance features through the use of the items listed below:

- (1) High performance and reliability
- (2) Low noise and vibration
- (3) Lightweight and compact design
- (4) Good serviceability
- (5) Clean emission and fuel economy

Section	Item	(1)	(2)	(3)	(4)	(5)
Engine Proper	A cylinder head cover made of magnesium alloy is used.			○		
	A taper squish shape is used for the combustion chamber.	○				○
	Spiny-type liners are used in the cylinder bores.	○		○		○
	A water jacket spacer is used.	○				○
	The piston skirt is coated with resin.	○	○			○
	Low tension piston rings are used.	○				○
	A resin gear balance shaft is used.		○	○		
Valve Mechanism	A timing chain and chain tensioner are used.		○		○	
	Hydraulic lash adjusters are used.		○		○	
	Roller rocker arms are used.	○				○
Lubrication System	An oil filter with a replaceable element is used.				○	
Cooling System	TOYOTA Genuine SLLC (Super Long Life Coolant) is used.				○	
Intake and Exhaust System	A charcoal filter is used in the air cleaner cap.					○
	An intake manifold made of plastic is used.			○		
	A linkless-type throttle body is used.			○	○	○
	A thin-wall ceramic TWC (Three-Way Catalytic converter) is used.					○
Fuel System	A fuel returnless system is used.			○	○	○
	Quick connectors are used to connect the fuel hose with the fuel pipe.			○	○	○
	12-hole type fuel injectors with high atomizing performance are used.	○				○
Ignition System	Long-reach type iridium-tipped spark plugs are used.	○			○	○
Charging System	A segment conductor type generator is used.	○	○	○		
Starting System	A PS (Planetary reduction-Segment conductor motor) type starter is used.	○		○		
Serpentine Belt Drive System	A serpentine belt drive system is used.			○	○	

(Continued)

Section	Item	(1)	(2)	(3)	(4)	(5)
Engine Control System	The DIS (Direct Ignition System) makes ignition timing adjustment unnecessary.	<input type="radio"/>			<input type="radio"/>	<input type="radio"/>
	An ETCS-i (Electronic Throttle Control System-intelligent) is used.	<input type="radio"/>				<input type="radio"/>
	A Dual VVT-i (Variable Valve Timing-intelligent) system is used.	<input type="radio"/>				<input type="radio"/>
	An ACIS (Acoustic Control Induction System) is used.	<input type="radio"/>				<input type="radio"/>
	A tumble control system is used.	<input type="radio"/>				<input type="radio"/>
	A starter control (cranking hold function) is used.*	<input type="radio"/>				

\*: Models with smart key system

### 3. Engine Proper

#### Cylinder Head Cover

- A lightweight magnesium alloy die-cast cylinder head cover is used.
- An oil delivery pipe is installed inside the cylinder head cover. This ensures lubrication to the sliding parts of the roller rocker arm, improving reliability.

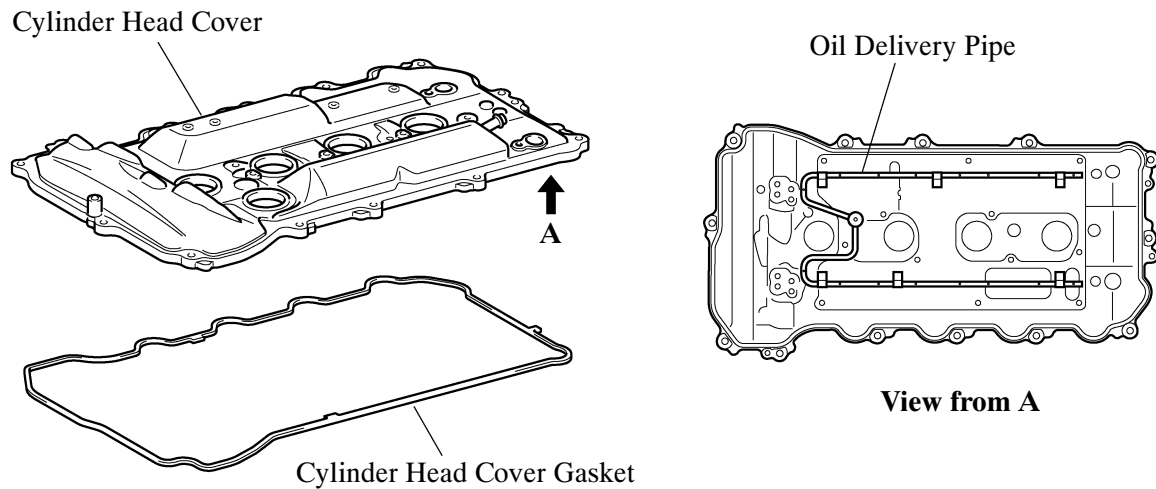

10SEG08Y

#### Cylinder Head Gasket

- A triple-layer metal type cylinder head gasket is used.
- The surface of the cylinder head gasket is coated with fluoro rubber to ensure a high level of reliability.

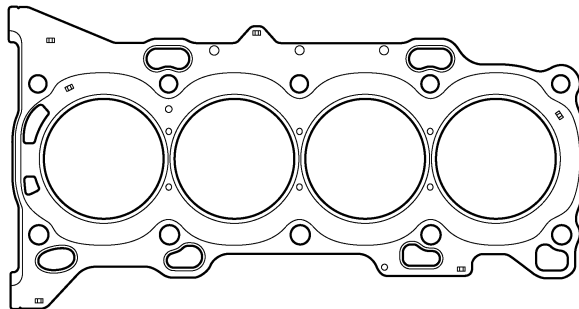

10SEG09Y

## Cylinder Head

- The cylinder head structure has been simplified by separating the camshaft housing (cam journal portion) from the cylinder head.
- The cylinder head, which is made of aluminum, contains a pentroof-type combustion chamber. The spark plug is located in the center of the combustion chamber in order to improve the engine's anti-knocking performance.
- A taper squish combustion chamber is used to improve anti-knocking performance. In addition, engine performance and fuel economy have been improved.
- Long nozzle type fuel injectors are installed in the cylinder head to reduce the distance from injector to intake valve, thus preventing the fuel from adhering to the intake port walls, and reducing HC exhaust emissions.

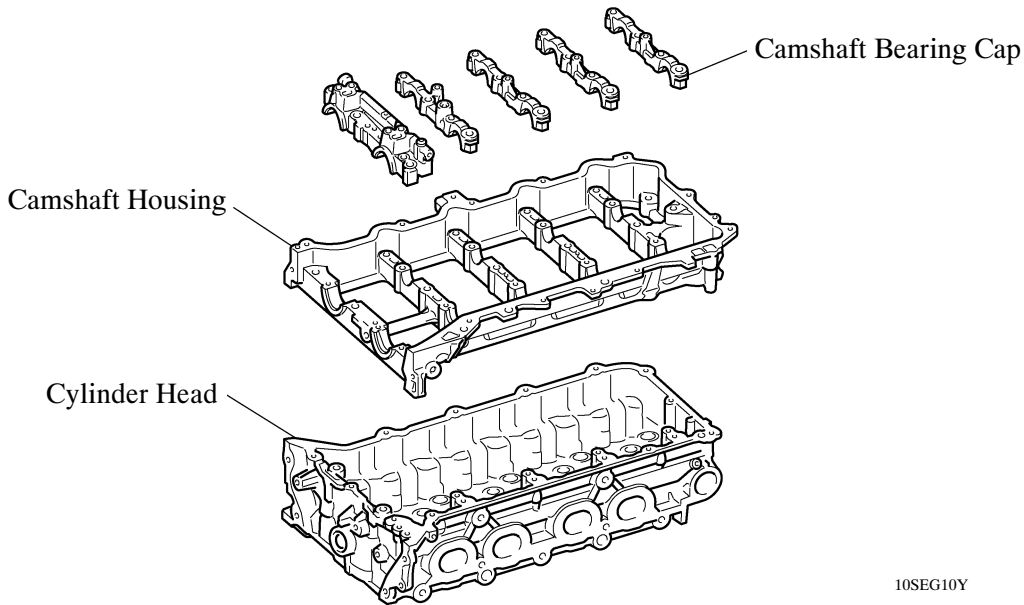

10SEG10Y

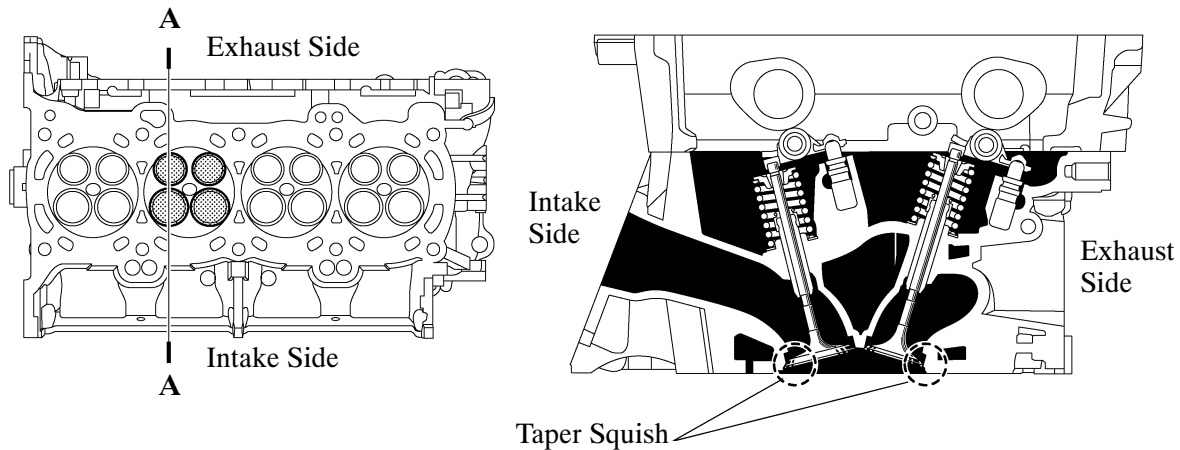

**A - A Cross Section**

10SEG11Y

## Cylinder Block

- Water passages have been provided between the cylinder bores. By allowing the engine coolant to flow between the cylinder bores, this construction enables the temperature of the cylinder walls to be kept uniform.
- The liners are the spiny-type, which have been manufactured so that their casting exteriors form large irregular surfaces in order to enhance the adhesion between the liners and the aluminum cylinder block. The enhanced adhesion helps heat dissipation, resulting in a lower overall temperature and heat deformation of the cylinder bores.
- Blowby gas passages are provided in the crankcase.
- Oil drain passages are provided in the crankcase. This prevents the crankshaft from mixing the engine oil, which reduces rotational resistance.
- The oil filter bracket is integrated into the crankcase.

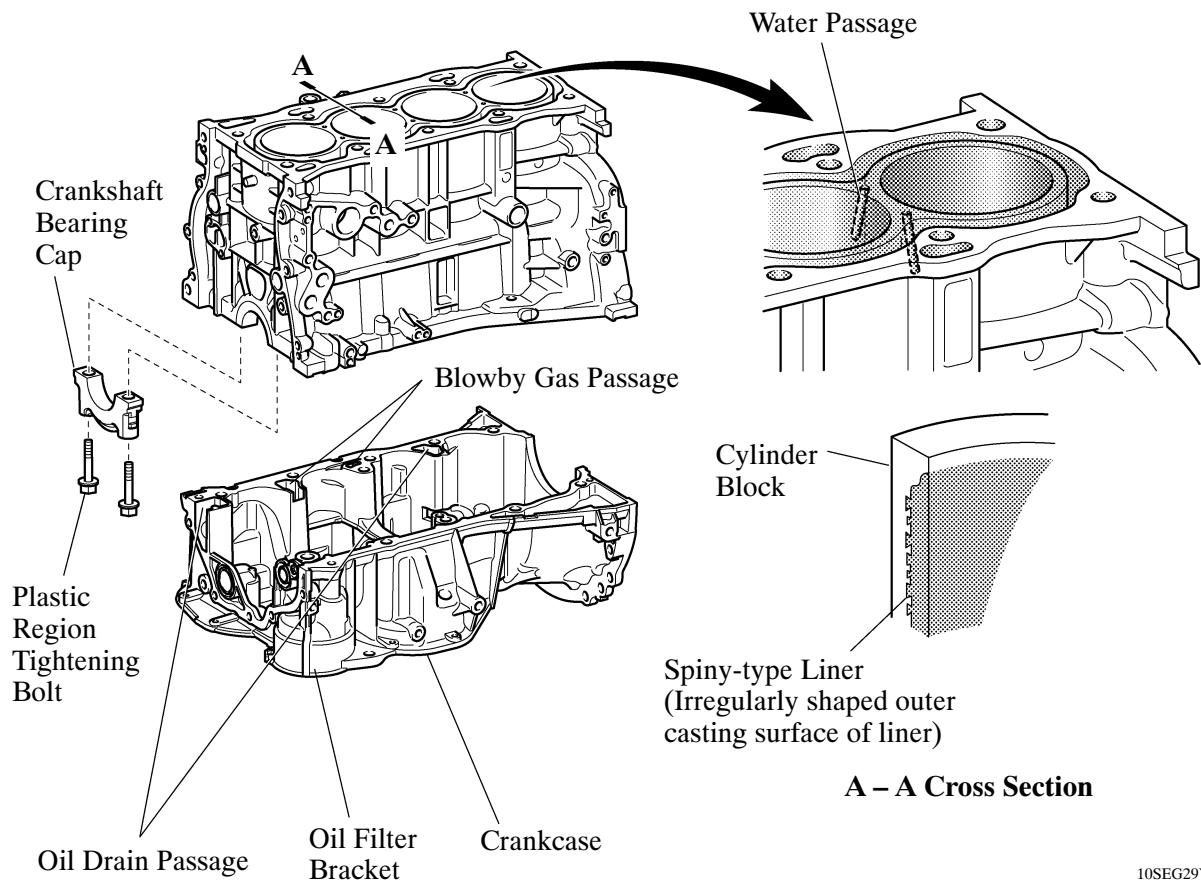



- An oil separator is provided in the blowby gas passage inside the cylinder block. This separates the engine oil from the blowby gas in order to reduce the degradation and consumption of volume of the engine oil.

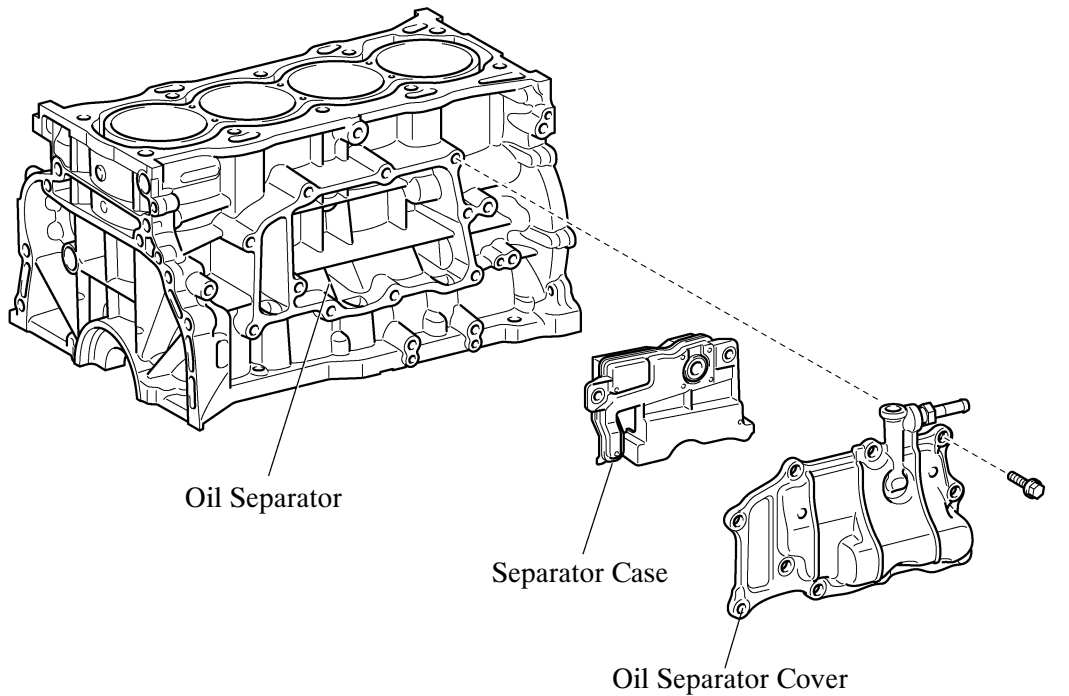

10SEG30Y

- Through the use of the offset crankshaft, the bore center is shifted 10 mm (0.39 in.) towards the exhaust, in relation to the crankshaft center. Thus, the side force to the cylinder wall is reduced when the maximum pressure is applied, which contributes to fuel economy.

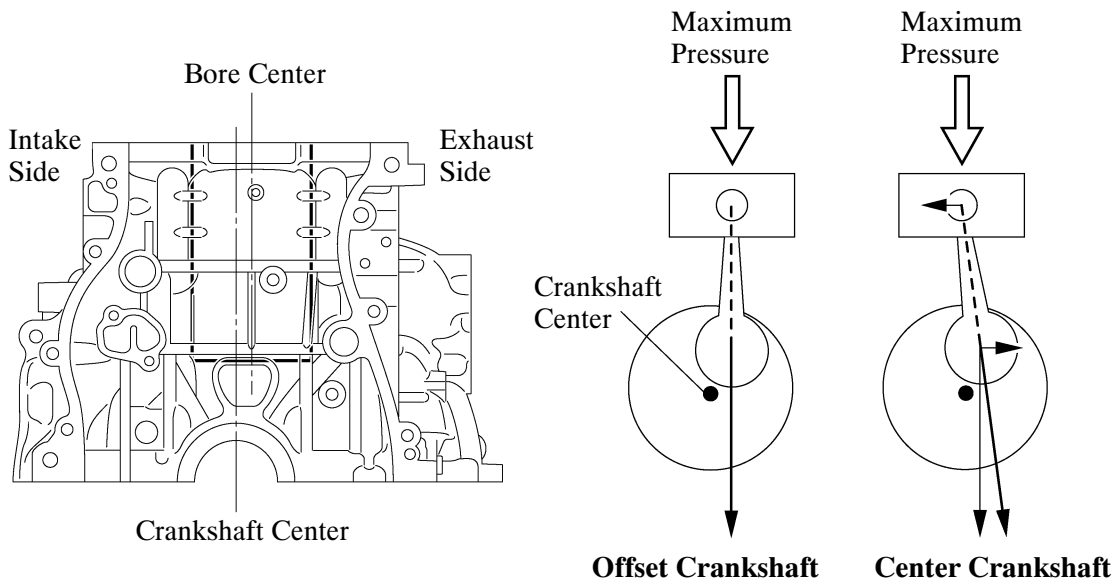

10SEG31Y

- A shallow bottom water jacket is used. The resulting reduction in the volume of the engine coolant improves warm-up performance, which contributes to improved fuel economy.
- The water jacket spacer is provided in the water jacket of the cylinder block.
- The water jacket spacer suppresses the water flow in the bottom of the water jackets, guides the coolant in the upper area of the water jacket, and ensures uniform temperature distribution. As a result, the viscosity of the engine oil that acts as a lubricant between the bore walls and the pistons can be lowered, thus reducing friction.

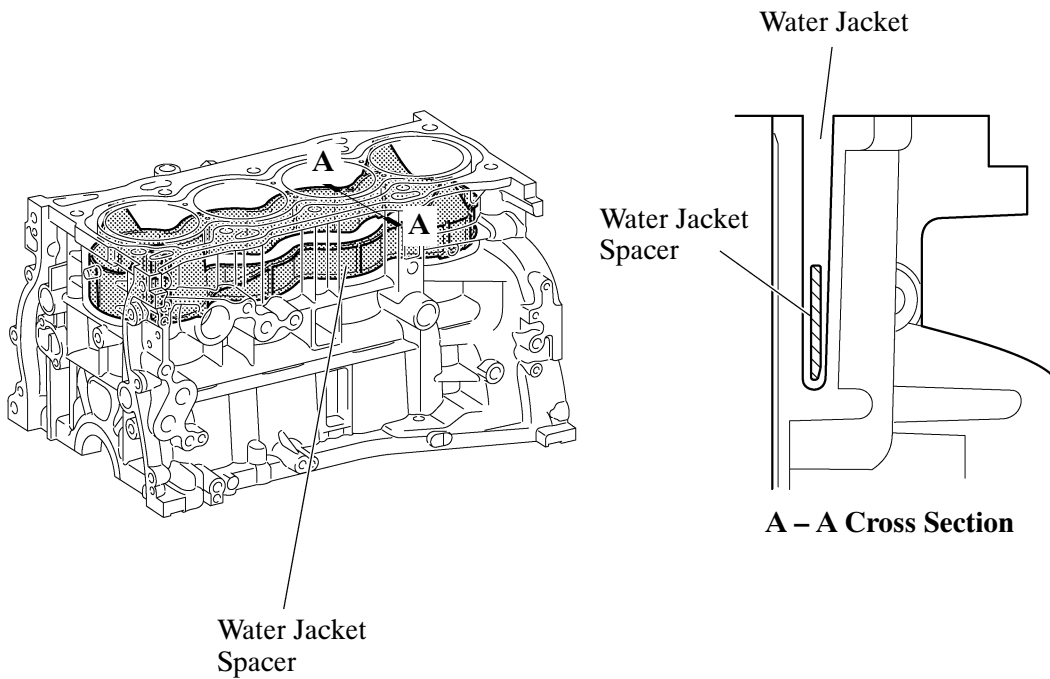

## Piston

- The piston is made of aluminum alloy and the skirt area is made compact and lightweight.
- The piston head portion uses a taper squish shape to improve the fuel combustion efficiency.
- The piston skirt has been coated with resin to reduce the friction loss.
- The groove of the top ring is coated with anodic oxide to improve wear resistance and corrosion resistance.
- Low-tension piston rings are used to reduce friction and achieve excellent fuel economy.
- Narrow-width piston rings are used to reduce weight and friction.
- A No. 1 compression ring with an inside bevel shape is used.
- A PVD (Physical Vapor Deposition) coating has been applied to the surface of the No. 1 compression ring, in order to improve its wear resistance.

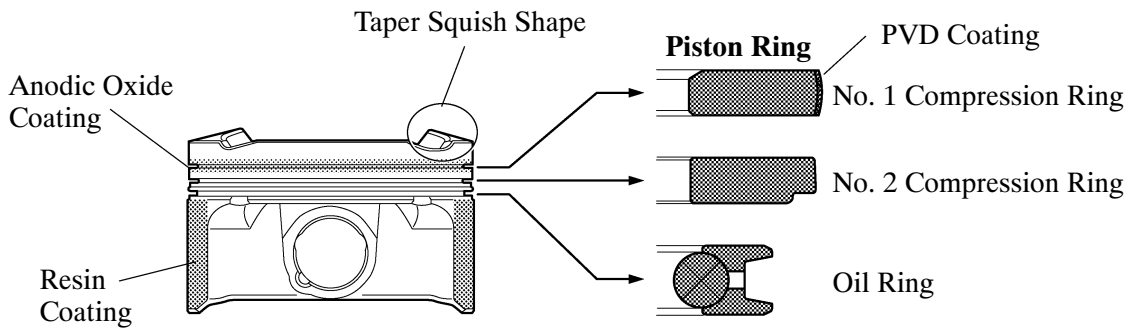

10SEG12Y

## Connecting Rod

- The connecting rods and caps are made of microalloyed steel.
- Plastic region tightening bolts are used on the connecting rod.
- The connecting rod bearings are reduced in width to reduce friction.
- The lining surface of the connecting rod bearing has been micro-grooved to achieve an optimal amount of oil clearance. As a result, cold-engine cranking performance has been improved and engine vibrations have been reduced.

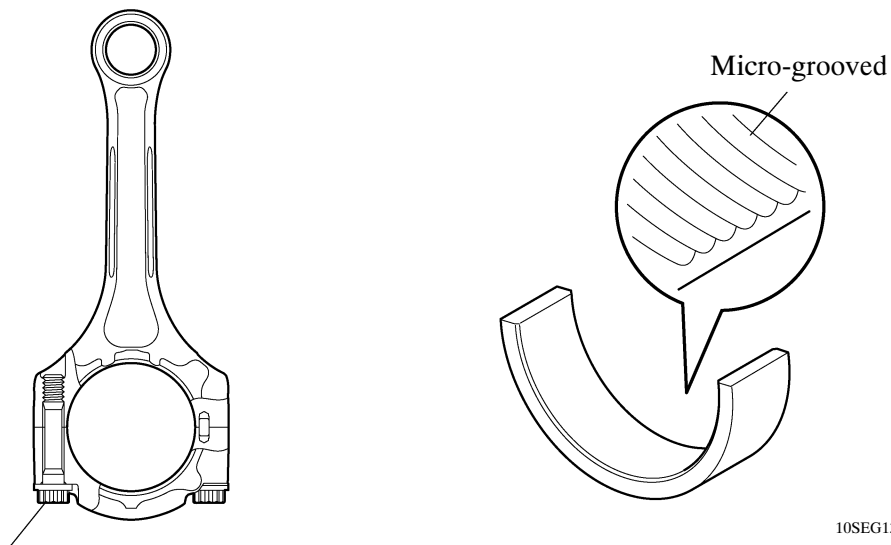

10SEG13Y

Plastic Region Tightening Bolt

## Crankshaft

- The crankshaft is made of microalloyed steel. It has 5 journals and 8 balance weights.
- A balance shaft drive gear is provided for the crankshaft.
- The crankshaft bearings are reduced in width to reduce friction.
- The lining surface of the crankshaft bearing has been micro-grooved to achieve an optimal amount of oil clearance. As a result, cold-engine cranking performance has been improved and engine vibrations have been reduced.
- The oil groove on the crankshaft bearing is made eccentric to reduce the amount of oil leakage from the bearing. This enables the capacity of the oil pump to be reduced in order to achieve a low friction operation.

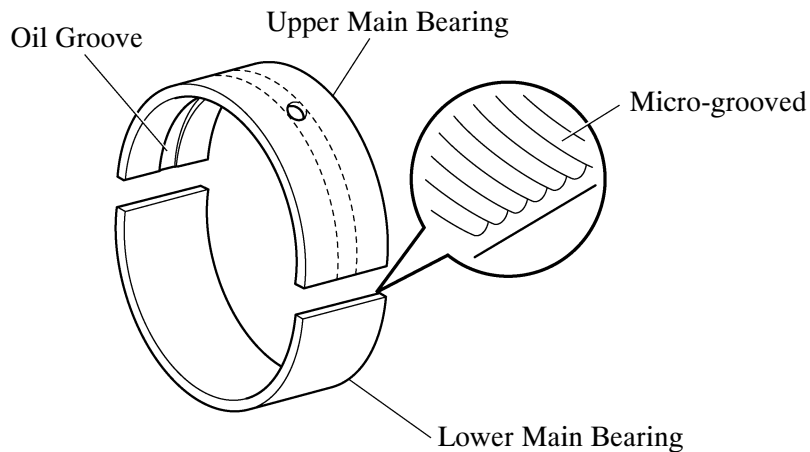
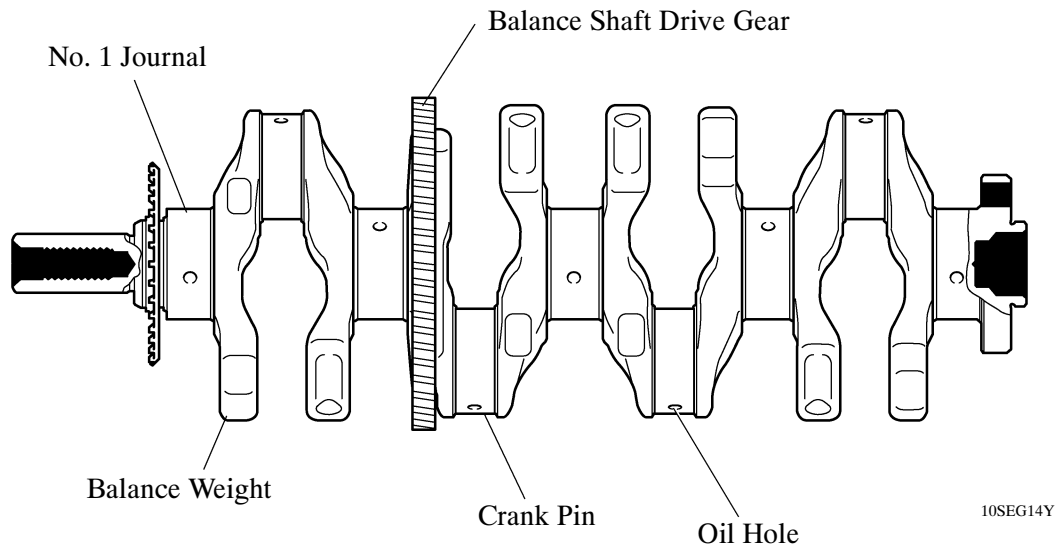

## Balance Shaft

### 1) General

- A balance shaft is used to reduce vibrations.
- The crankshaft directly drives the No. 1 balance shaft.
- In addition, a resin gear is used on the driven side to suppress noise and offer lightweight design.

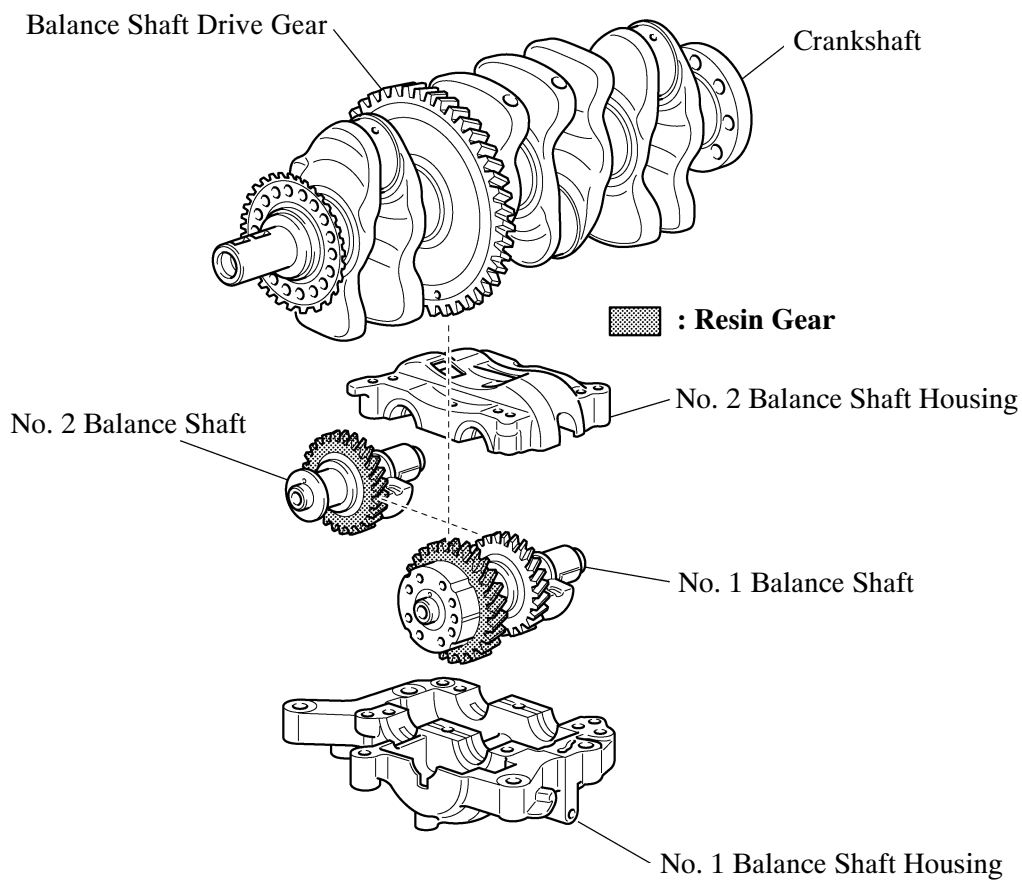

**2) Operation**

In the in-line 4-cylinder engine, the crankshaft angle for cylinders No. 1 and No. 4 are at exactly the opposite (180°) position of cylinders No. 2 and No. 3. Therefore, the inertial force of the pistons and the connecting rods of the former 2 cylinders and of the latter 2 cylinders almost cancel each other out. However, because the position at which the piston reaches its maximum speed is located toward the top dead center from the center of the stroke, the upward inertial force is greater than the downward inertial force. This unbalanced secondary inertial force is generated twice for each rotation of the crankshaft.

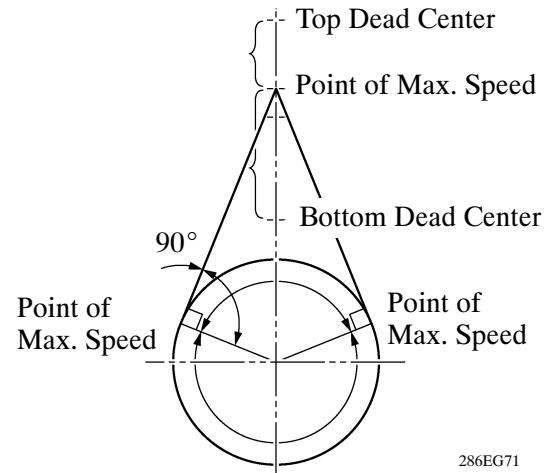

286EG71

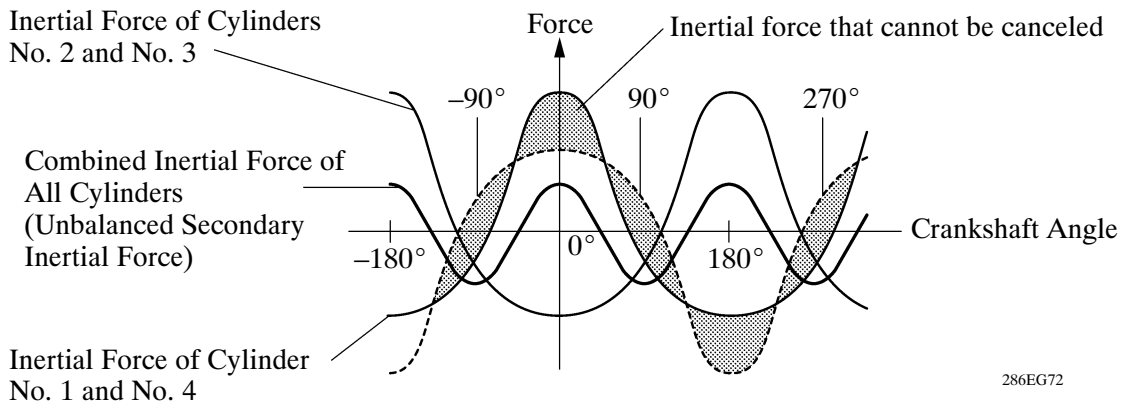

286EG72

**Inertial Force Generated by the In-line 4 Cylinders**

To cancel the unbalanced secondary inertial force, 2 balance shafts are rotated twice for each rotation of the crankshaft and generate inertial force in the opposite direction. Also, in order to cancel the inertial force generated by the balance shaft itself, the balance shaft actually consists of 2 shafts rotating in opposite directions.

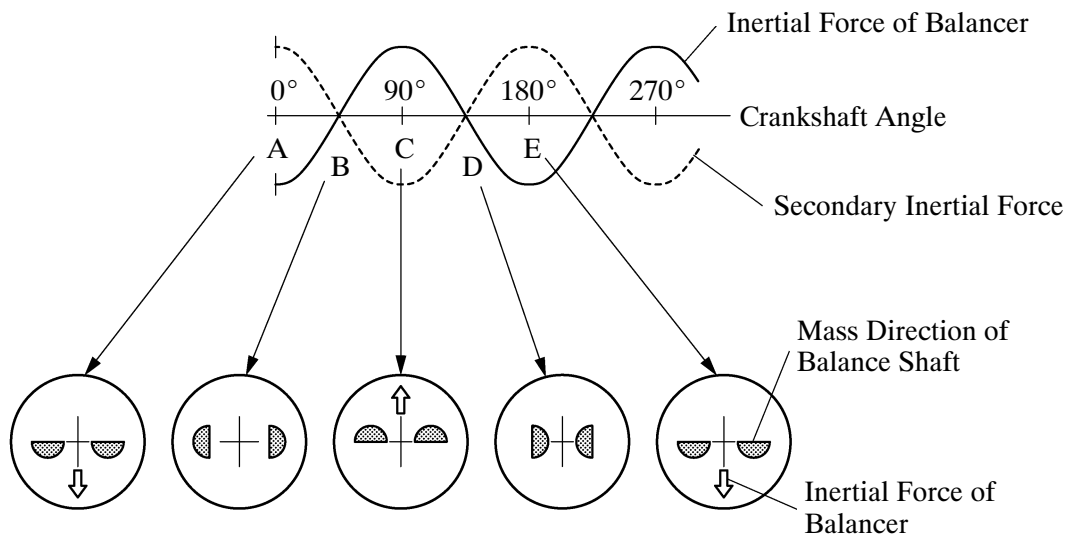

**Mass Direction of Balance Shaft at Crankshaft Angle**

10SEG71Y

## 4. Valve Mechanism

### General

- The Dual VVT-i system is used to improve fuel economy and engine performance and reduce exhaust emissions. For details of Dual VVT-i system, see page 72.
- The intake and exhaust camshafts are driven by a timing chain.
- The roller rocker arms with built-in needle bearings are used. This reduces the friction that occurs between the cams and the areas (roller rocker arms) that push the valves down, thus improving fuel economy.
- The hydraulic lash adjusters, which maintain a constant zero valve clearance through the use of oil pressure and spring force, are used.

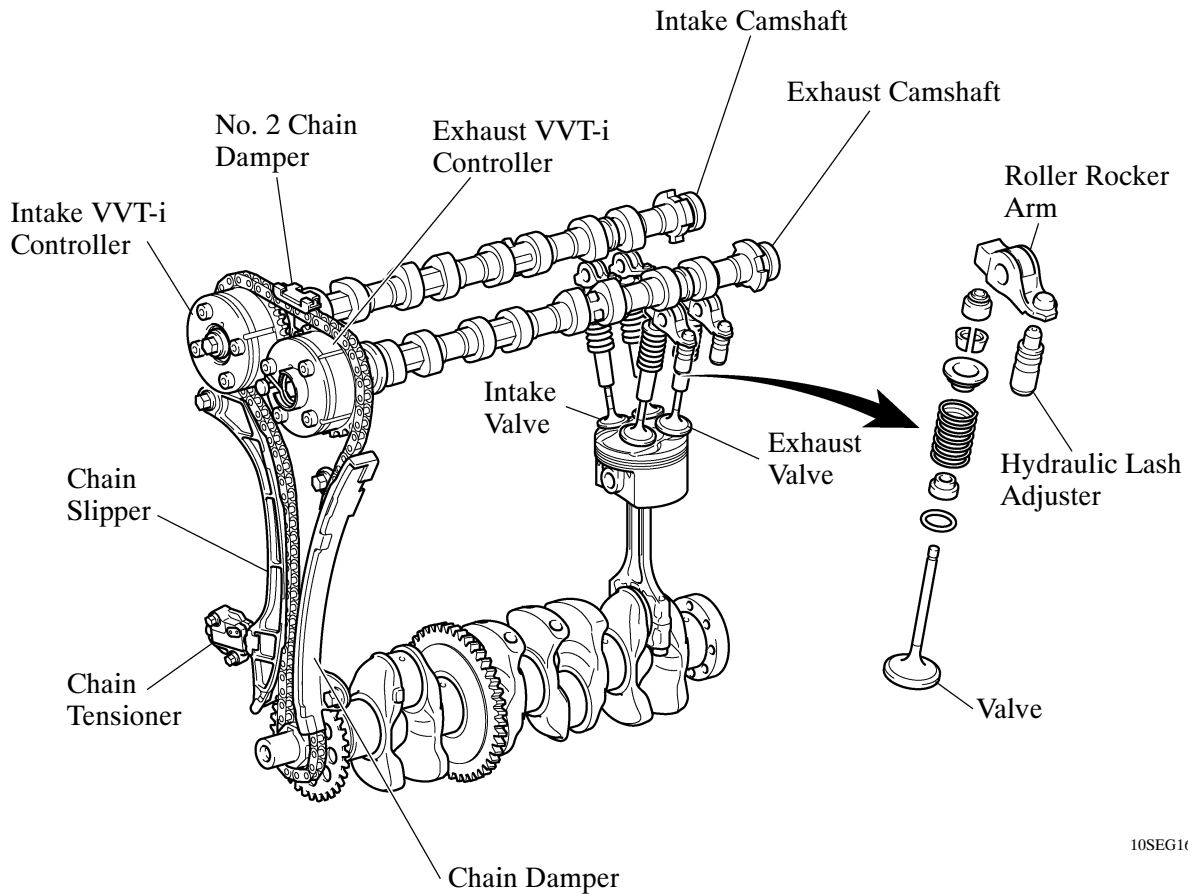

## Camshaft

- An oil passage is provided in the intake and exhaust camshafts in order to supply engine oil to the Dual VVT-i system.
- A VVT-i controller has been installed on each front of the intake and exhaust camshafts to vary the timing of the intake and exhaust valves.
- Together with the use of the roller rocker arm, the cam profile has been designed with an indented R (radius). This results in increased valve lift when the valve begins to open and finishes closing, helping to achieve enhanced output performance.
- A timing rotor for the camshaft position sensor is provided at each back end of the intake and exhaust camshafts.

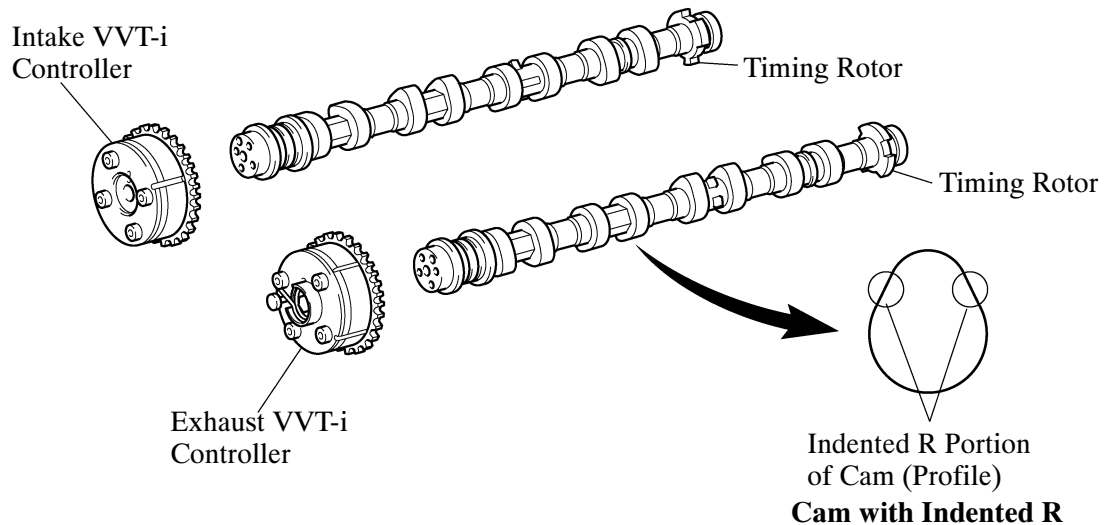

10SEG17Y

## Timing Chain

- A roller chain with a 9.525 mm (0.375 in.) pitch is used.
- The timing chain is lubricated by a timing chain oil jet. See page 30 for the location of the timing chain oil jet.
- The chain tensioner uses a spring and oil pressure to maintain proper chain tension at all times. The chain tensioner suppresses noise generated by the timing chain.
- The chain tensioner is ratchet type with a non-return mechanism.
- To achieve excellent serviceability, the chain tensioner is constructed so that it can be removed and installed from the outside of the timing chain cover.

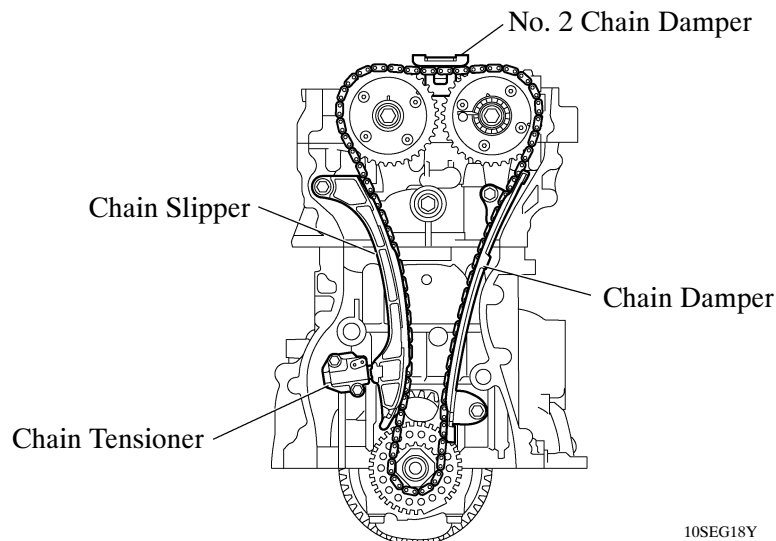

10SEG18Y



## Hydraulic Lash Adjuster

- The hydraulic lash adjuster, which is located at the fulcrum of the roller rocker arm, consists primarily of a plunger, plunger spring, check ball, and check ball spring.
- The engine oil supplied by the cylinder head and the built-in spring actuates the hydraulic lash adjuster. The oil pressure and the spring force that act on the plunger push the roller rocker arm against the cam, in order to adjust the valve clearance that is created during the opening and closing of the valve. As a result, engine noise has been reduced.

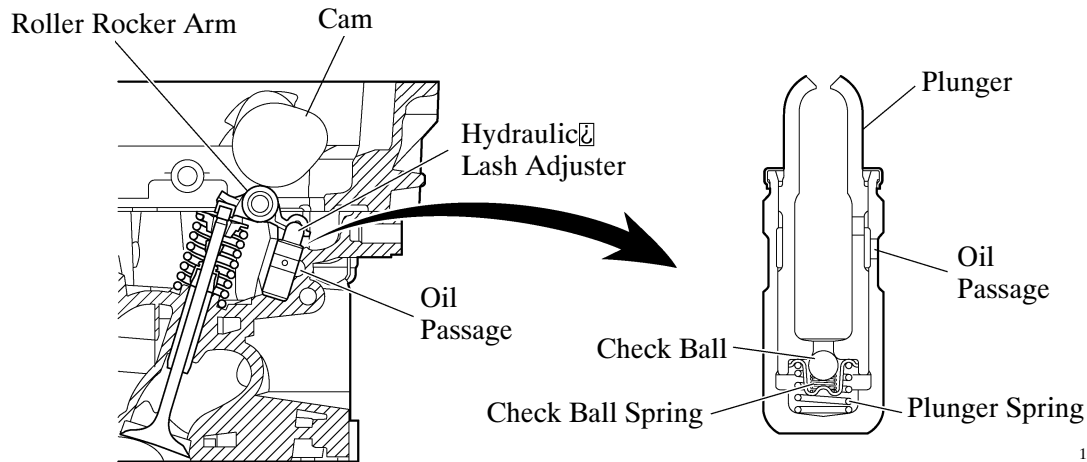

10SEG19Y

### Service Tip

Valve clearance adjustment is not necessary because a hydraulic lash adjuster is used.

## Timing Chain Cover

- An aluminum die-cast timing chain cover is used.
- The timing chain cover has an integrated construction consisting of the oil pump and timing chain oil jet. Thus, the number of parts has been reduced, resulting in a weight reduction.
- To achieve excellent serviceability, service holes for the chain tensioner and intake VVT are provided on the timing chain cover.

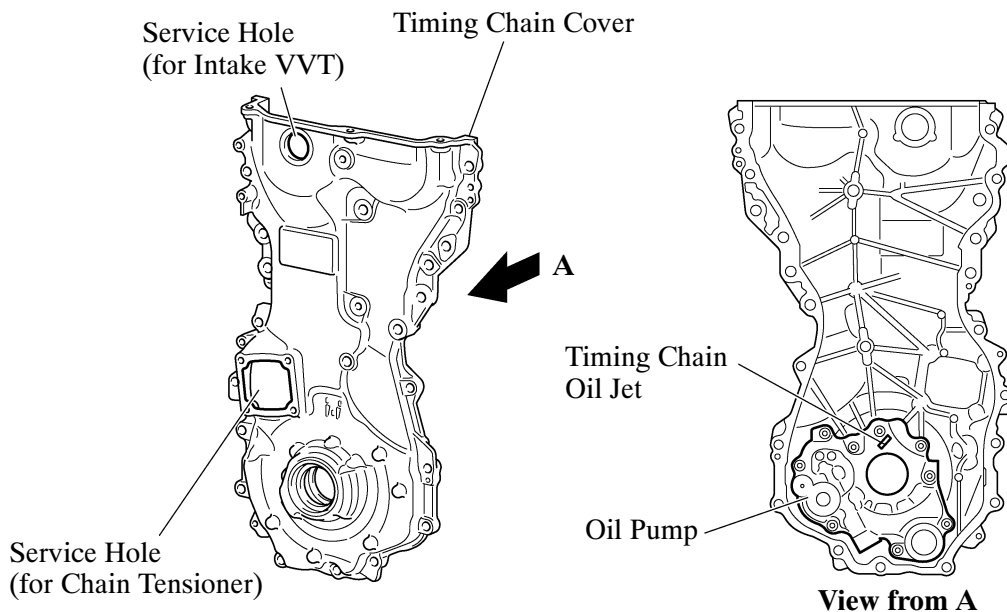

10SEG34Y

## 5. Lubrication System

### General

- The lubrication circuit is fully pressurized and oil passes through an oil filter.
- This engine has an oil return system in which the oil is force-fed to the upper cylinder head and returns to the oil pan through the oil return hole in the cylinder head.
- A cycloid rotor type oil pump is used. The oil pump is directly driven by the crankshaft.
- The Dual VVT-i system is used. This system is operated by the engine oil.

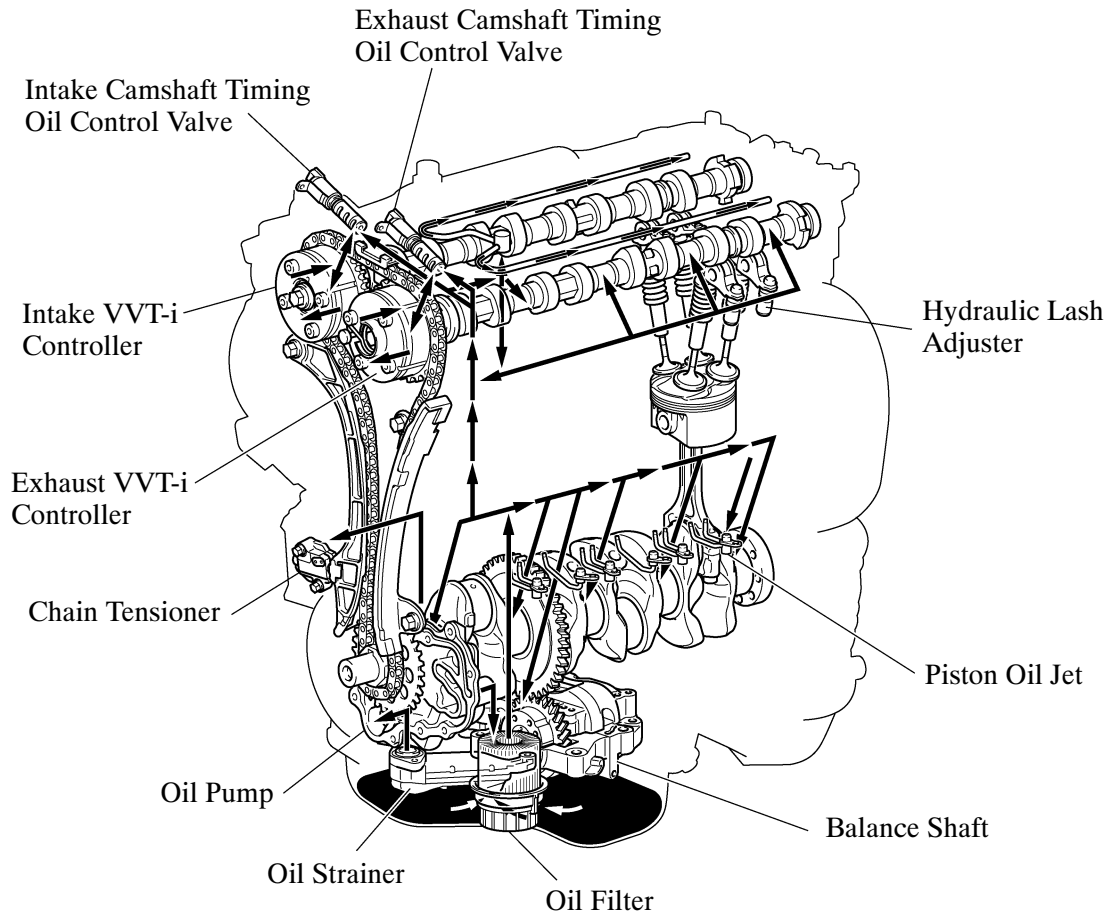

► Oil Circuit ◀

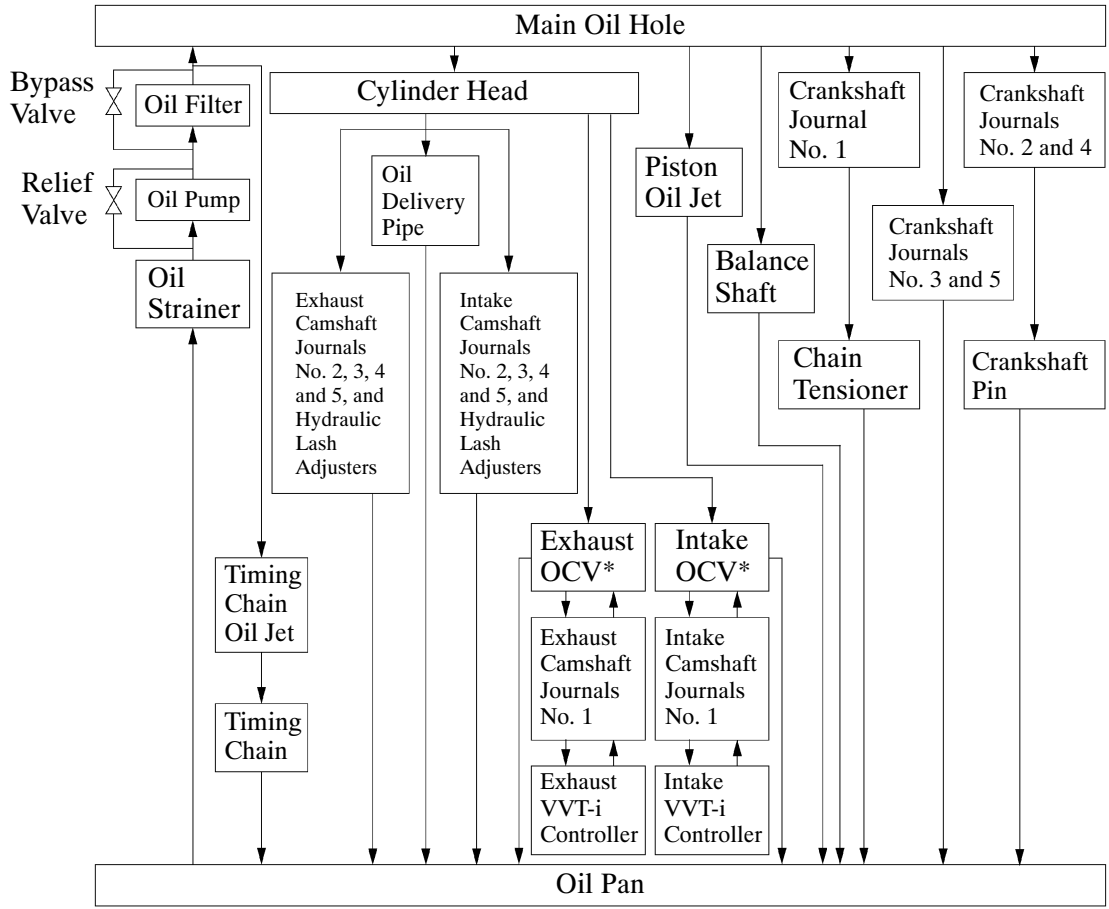

\*: OCV (Oil Control Valve)

10SEG64I

**Oil Jet**

- Piston oil jets for cooling and lubricating the pistons and bores are used in the cylinder block.
- These oil jets contain a check valve to prevent oil from being fed when the oil pressure is low. This prevents the overall oil pressure in the engine from dropping.

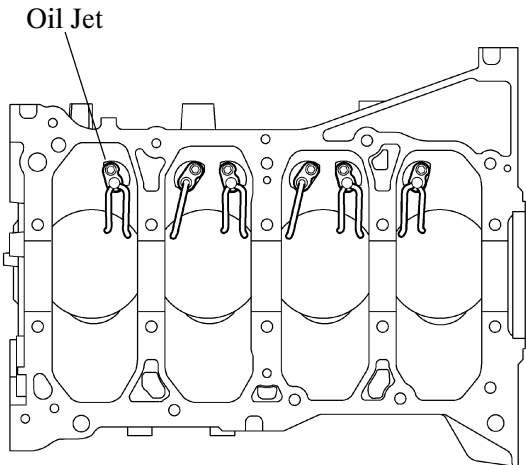

**Bottom Side View**

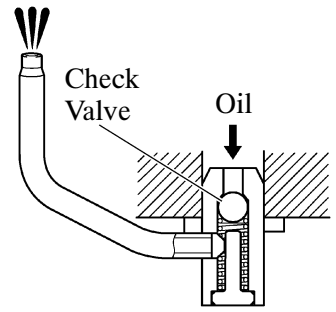

**Oil Jet Cross Section**

10SEG20Y

## Oil Filter

- An oil filter with a replaceable element is used. The element uses a high-performance filter paper to improve filtration performance. It is also combustible for environmental protection.
- A plastic filter cap is used for weight reduction.
- This oil filter has a structure which can drain the engine oil remaining in the oil filter. This prevents engine oil from spattering when replacing the element and allows the technician to work without touching hot engine oil.

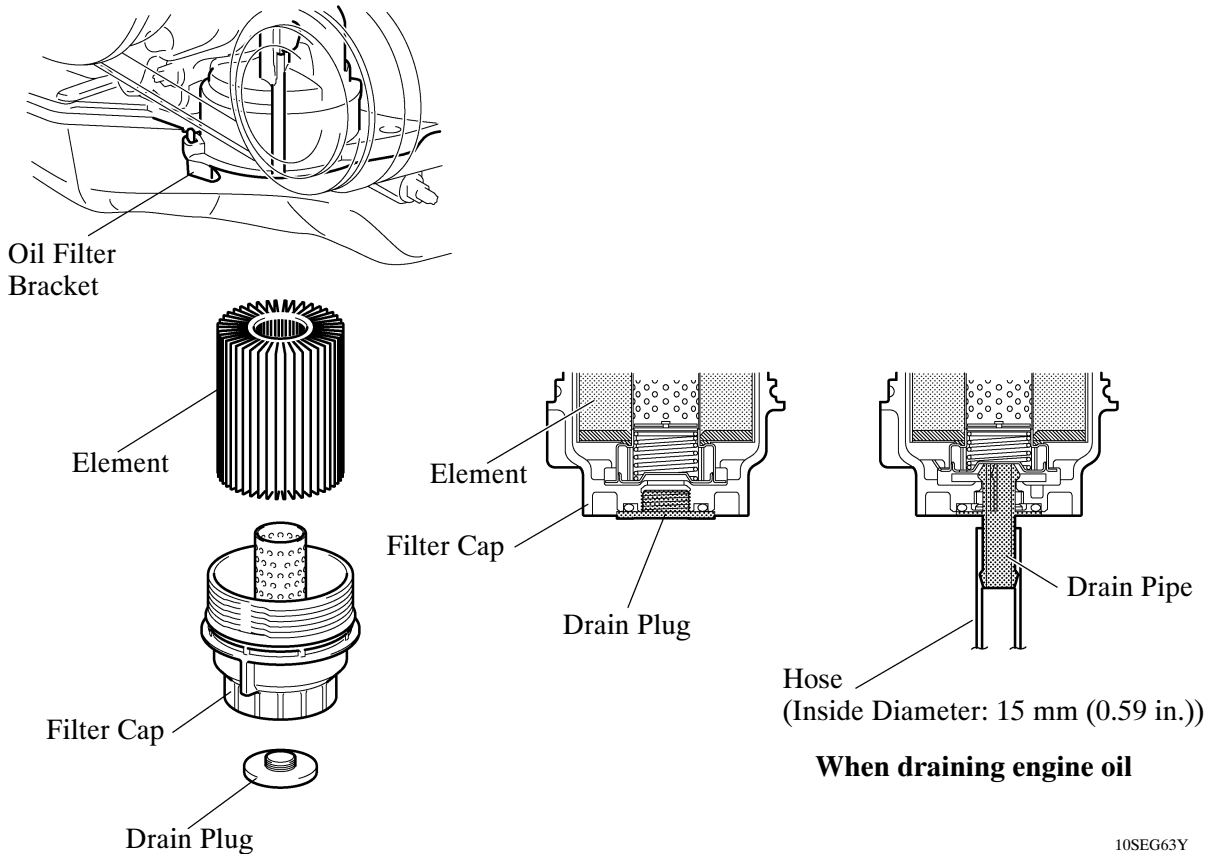

### Service Tip

- The engine oil in the oil filter can be drained by removing the drain plug and inserting the drain pipe supplied with the element into the oil filter. For details, refer to the 2009 RAV4 Repair Manual (Pub. No. RM10S0U).
- The engine oil maintenance interval for a model that has an oil filter with a replaceable element is the same as that for the conventional model.

10SEG63Y

## 6. Cooling System

- The cooling system uses a pressurized forced-circulation system with a pressurized reservoir tank.
- A thermostat with a bypass valve is located on the water inlet housing to maintain suitable temperature distribution in the cooling system.
- An aluminum radiator core is used for weight reduction.
- The flow of the engine coolant makes a U-turn in the cylinder block to ensure a smooth flow of the engine coolant. In addition, a bypass passage is enclosed in the cylinder head and the cylinder block.
- Warm engine coolant from the engine is sent to the throttle body to prevent freeze-up.
- TOYOTA Genuine SLLC (Super Long Life Coolant) is used.

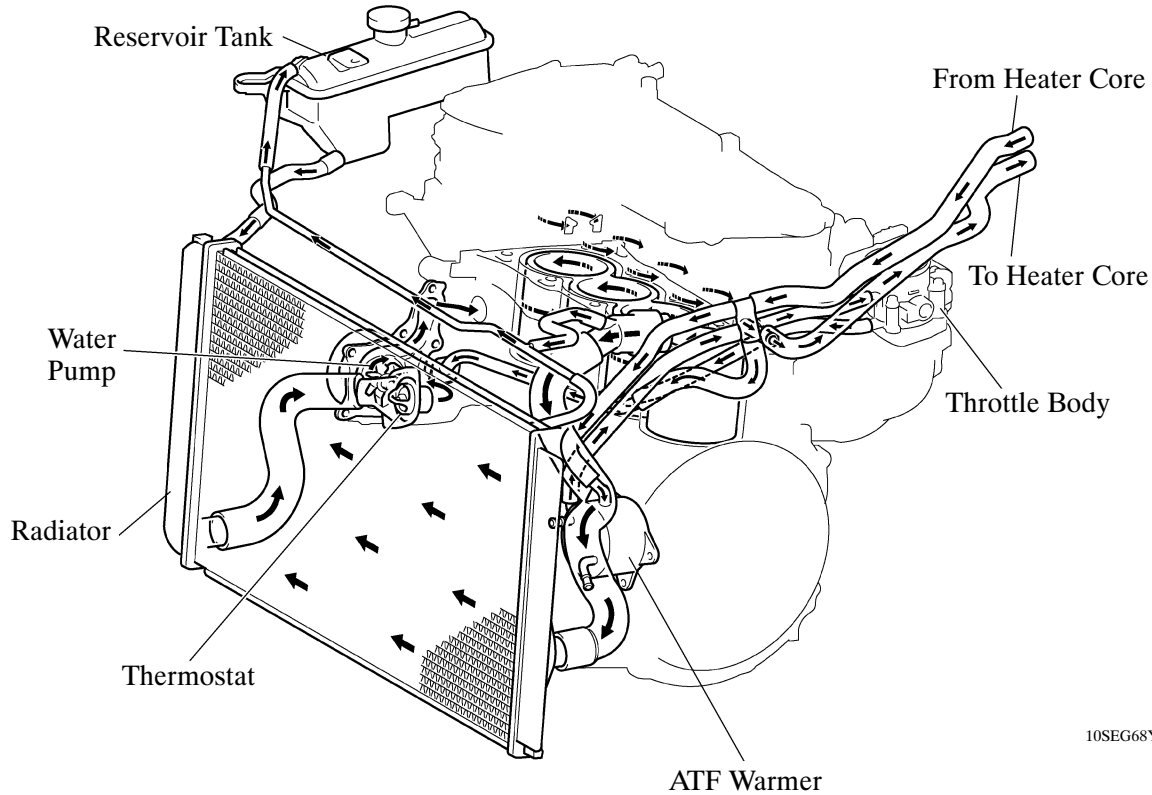

10SEG68Y

### ► System Diagram ◀

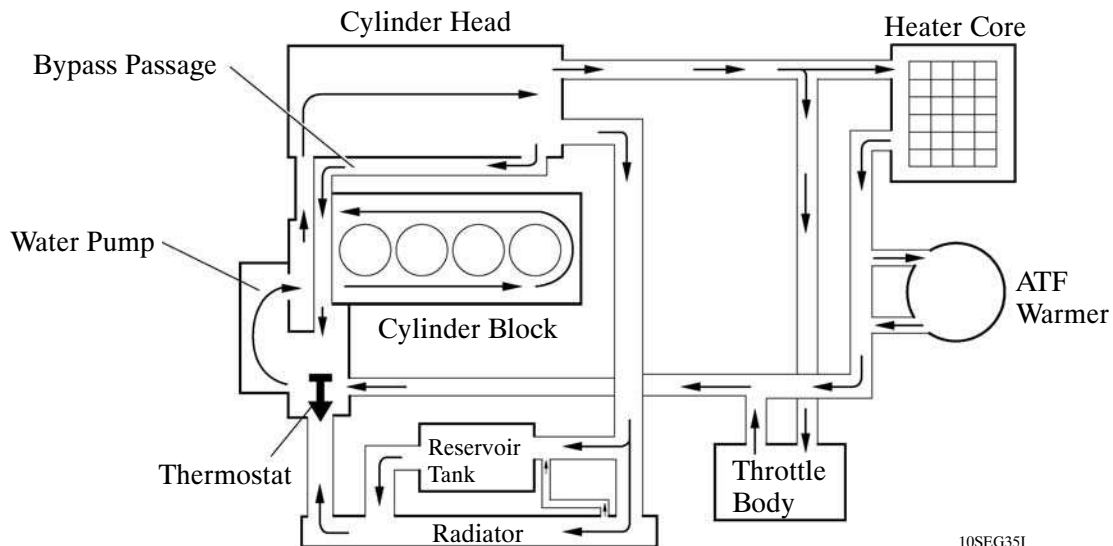

10SEG35I

## ► Specifications ◀

Engine Coolant	Type	TOYOTA genuine SLLC or similar high quality ethylene glycol based non-silicate, non-amine, non-nitrite and non-borate coolant with long-life hybrid organic acid technology (coolant with long-life hybrid organic acid technology is a combination of low phosphates and organic acids). Do not use plain water alone.	
	Color	Pink	
	Maintenance Intervals	First Time	100000 mile (160000 km)
Subsequent		Every 50000 mile (80000 km)	
Thermostat	Opening Temperature	80 – 84°C (176 – 183°F)	

- SLLC is pre-mixed (models for U.S.A.: 50% coolant and 50% deionized water, models for Canada: 55% coolant and 45% deionized water). Therefore, no dilution is needed when SLLC in the vehicle is added or replaced.
- If LLC (red-colored) is mixed with SLLC (pink-colored), the interval for LLC (every 25000 miles (models for U.S.A.), 32000 km (models for Canada) or 24 months whichever comes first) should be used.

## 7. Intake and Exhaust System

### General

- The linkless-type throttle body is used to achieve excellent throttle control.
- ETCS-i (Electronic Throttle Control System-intelligent) is used to provide excellent throttle control. For details, see page 67.
- A plastic intake manifold is used for weight reduction.
- A stainless steel exhaust manifold is used for weight reduction.
- The ACIS (Acoustic Control Induction System) is used to improve the engine performance. For details, see page 78.
- The tumble control system is used to improve the engine performance and reduce exhaust emissions. For details, see page 81.

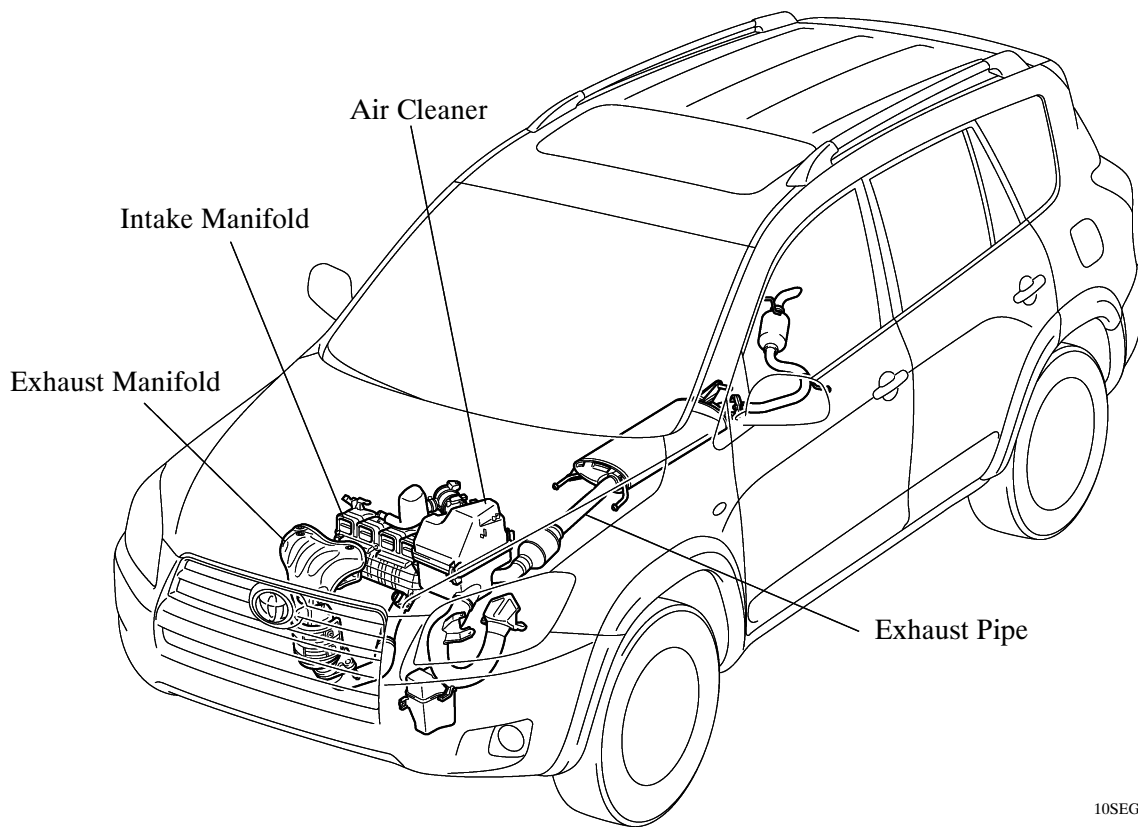

## Air Cleaner

- A nonwoven, full-fabric type air cleaner element is used.
- A charcoal filter, which absorbs the HC that accumulates in the intake system when the engine is stopped, is used in the air cleaner cap in order to reduce evaporative emissions.

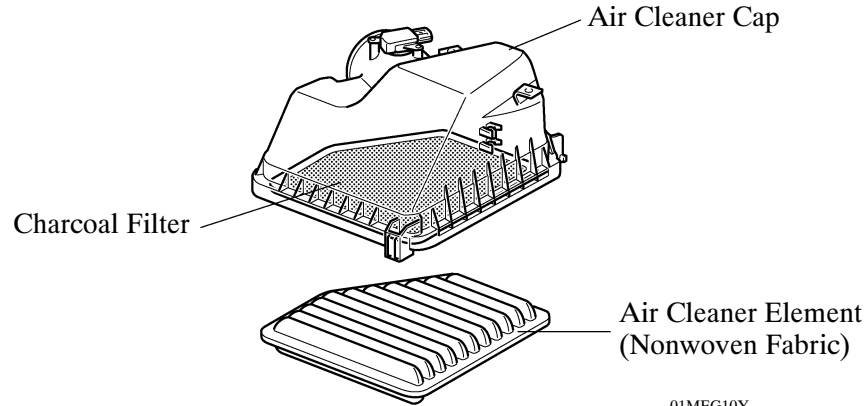

### Service Tip

The charcoal filter, which is maintenance-free, cannot be removed from the air cleaner cap.

## Throttle Body

- The linkless-type throttle body is used and it achieves excellent throttle control.
- A DC motor with excellent response and minimal power consumption is used for the throttle control motor. The ECM performs the duty cycle control of the direction and the amperage of the current that flows to the throttle control motor in order to regulate the opening angle of the throttle valve.

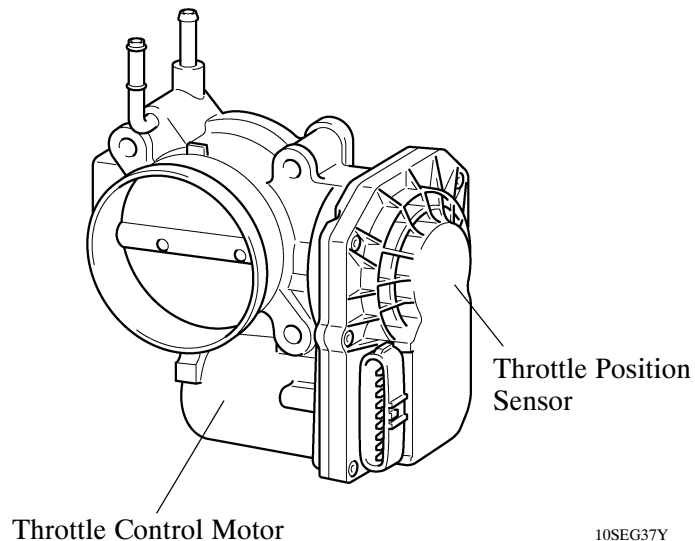



## Intake Manifold

- The intake manifold is made of lightweight plastic.
- A rotary type intake air control valve, which has less intake air resistance, is provided in the intake manifold. The intake air control valve is activated by the ACIS (Acoustic Control Induction System). For details, see page 78.
- The tumble control valve is provided in the intake manifold. The tumble control valve is activated by the tumble control system. For details, see page 81.
- A DC motor type actuator for the tumble control system, the vacuum type actuator for the ACIS and VSV for ACIS are provided to the intake manifold. The ACIS actuator is laser-welded onto the intake air chamber.
- A mesh type gasket is used between the throttle body and the intake manifold to improve the flow of air within the intake manifold.
- To achieve a compact configuration, the vacuum tank for the ACIS is located in the dead space of the intake manifold.

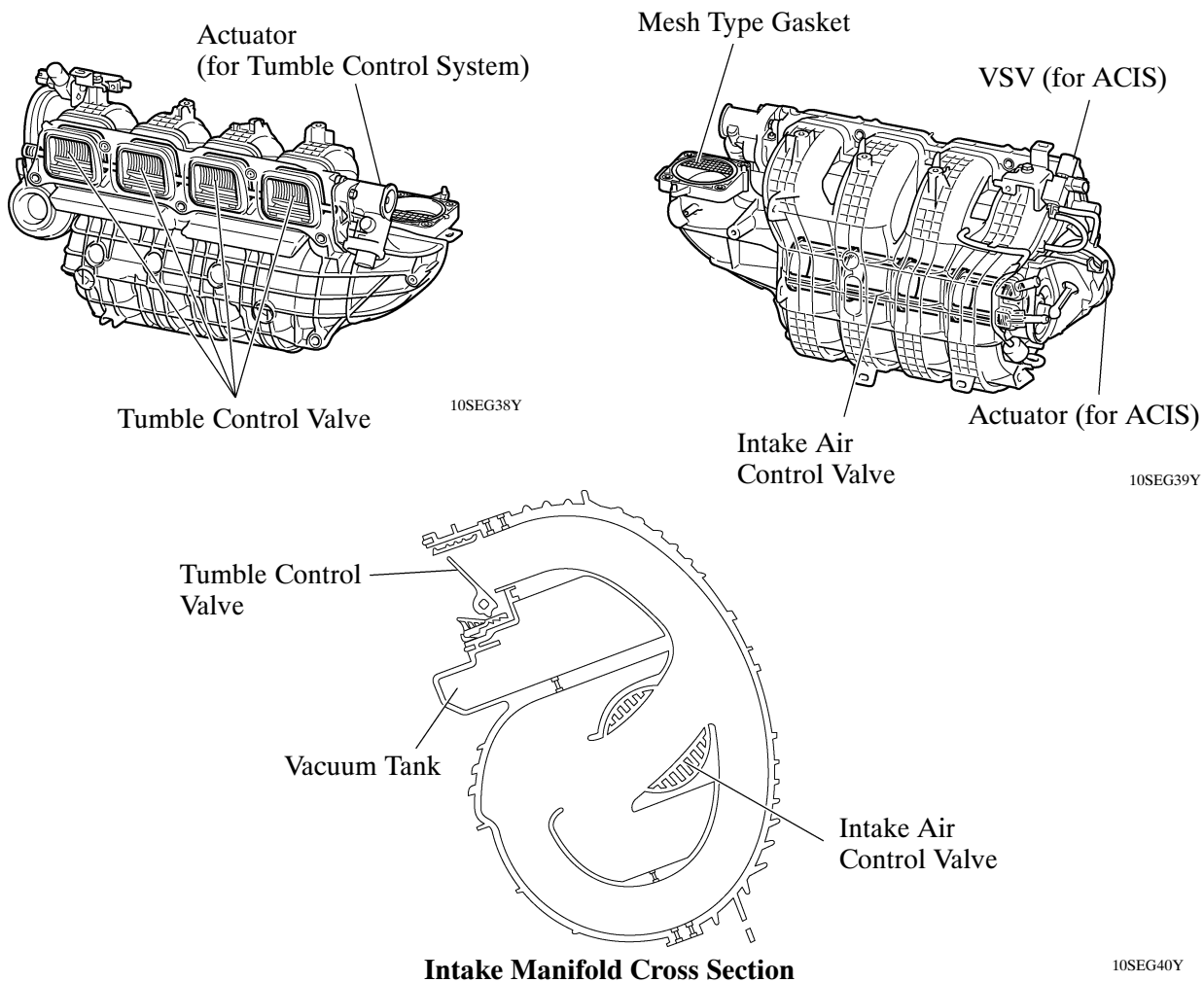

### — REFERENCE —

#### **Laser-welding:**

In laser-welding, a laser-absorbing material (for the intake manifold) is joined to a laser-transmitting material (for the ACIS actuator). Laser beams are then irradiated from the laser-transmitting side. The beams penetrate the laser-transmitting material to heat and melt the surface of the laser-absorbing material. Then, the heat of the laser-absorbing material melts the laser-transmitting material and causes both materials to become welded.

## Exhaust Manifold

A stainless steel exhaust manifold is used for improving the warm-up of the TWC (Three-Way Catalytic converter) and for weight reduction.

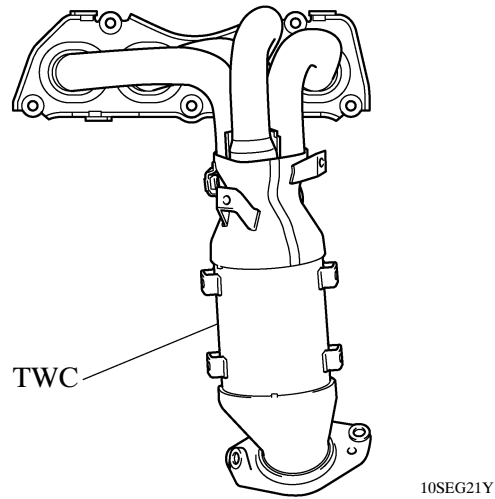

## Exhaust Pipe

- The exhaust pipe uses two ball joints in order to achieve a simple construction and ensured reliability.
- The TWC is used to reduce exhaust emissions.

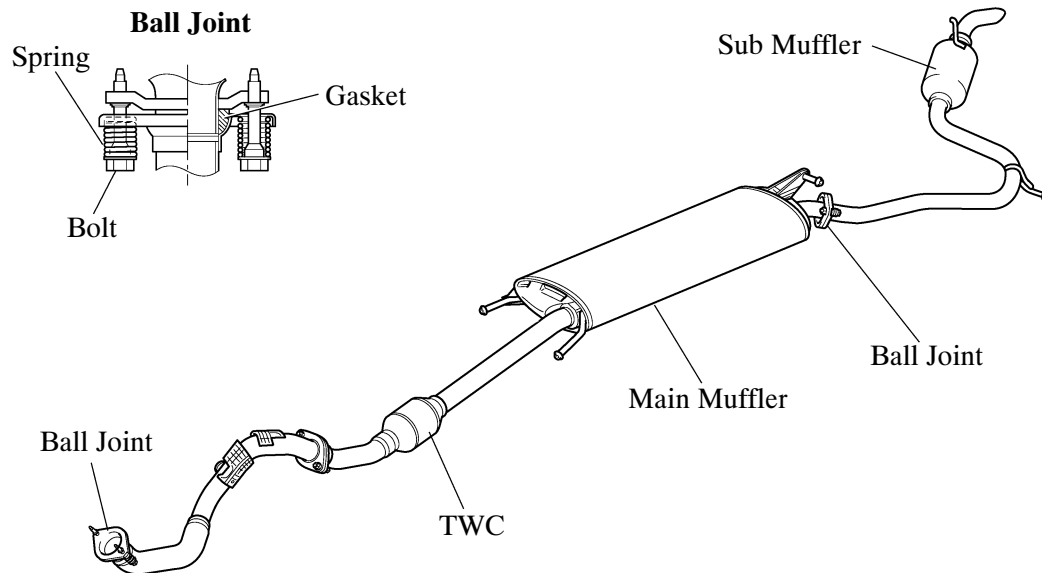

## 8. Fuel System

### General

- The fuel returnless system is used to reduce evaporative emissions.
- A fuel cut control is used to stop the fuel pump when the SRS airbag is deployed in a front or side collision. For details, see page 84.
- A quick connector is used in the fuel main pipe to improve serviceability.
- The long nozzle type fuel injector is used. This injector has 12 injection holes.
- The ORVR (On-board Refueling Vapor Recovery) system is used. For details, see page 87.

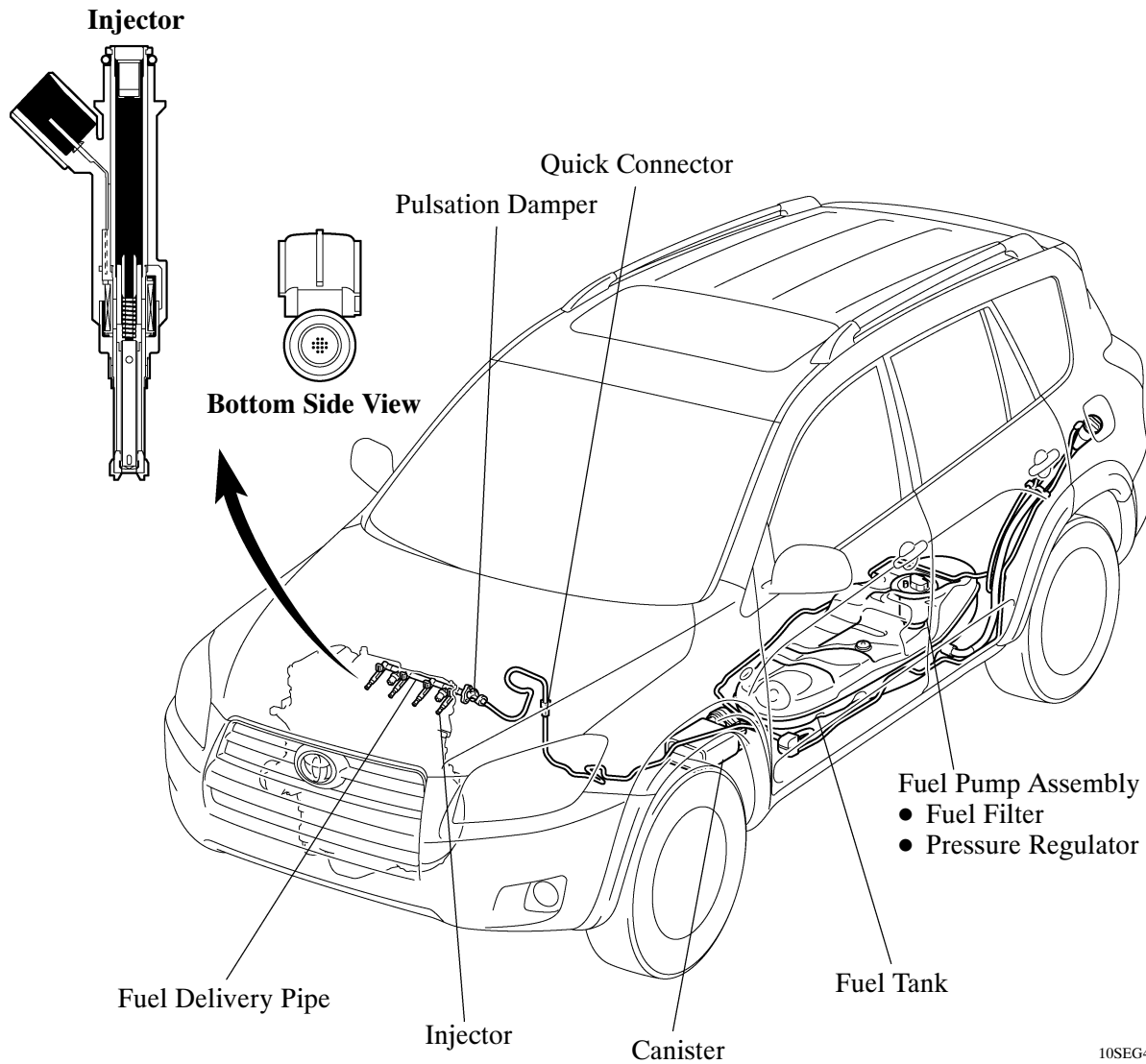

## Fuel Returnless System

The fuel returnless system is used to reduce the evaporative emission. As shown below, by integrating the fuel filter and pressure regulator with the fuel pump assembly, the fuel return system in which the fuel returns from the engine area has been discontinued and temperature rise inside the fuel tank is prevented.

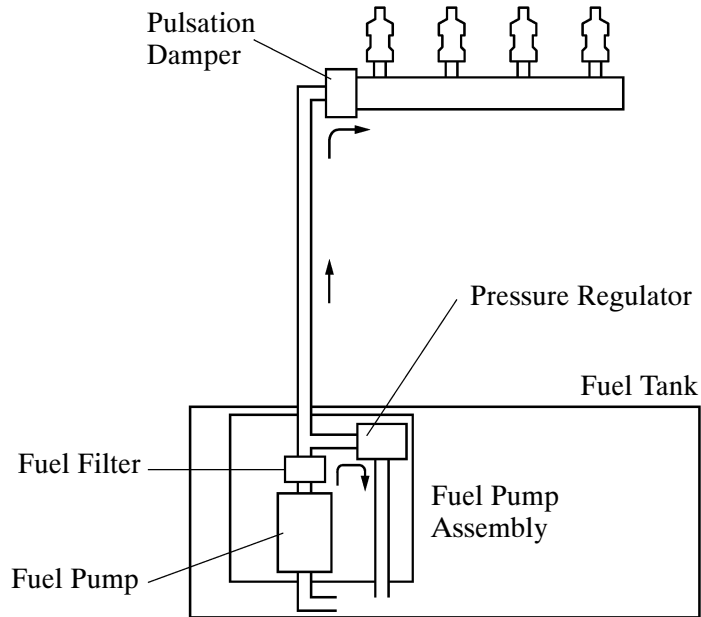

185EG16

## 9. Ignition System

### General

- A DIS (Direct Ignition System) is used. The DIS improves the ignition timing accuracy, reduces high-voltage loss, and enhances the overall reliability of the ignition system by eliminating the distributor.
- The DIS in this engine is an independent ignition system which has one ignition coil (with igniter) for each cylinder.
- Long-reach type iridium-tipped spark plugs are used.

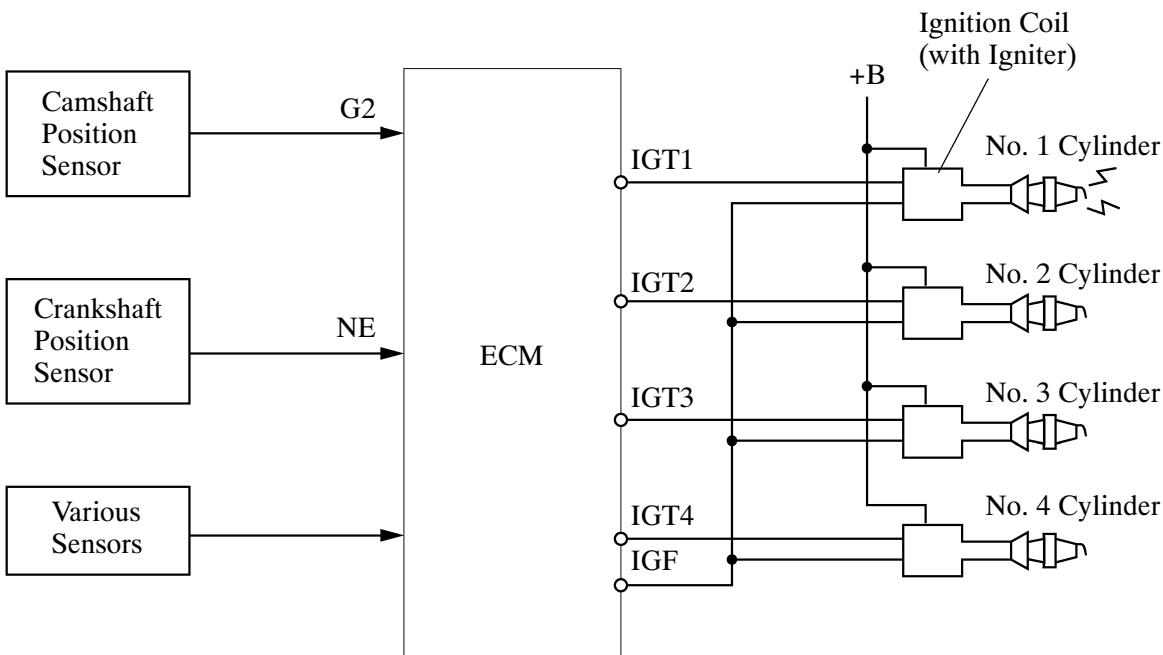

**Spark Plug**

Long-reach type iridium-tipped spark plugs are used to improve ignition performance while maintaining the same durability as platinum-tipped spark plugs.

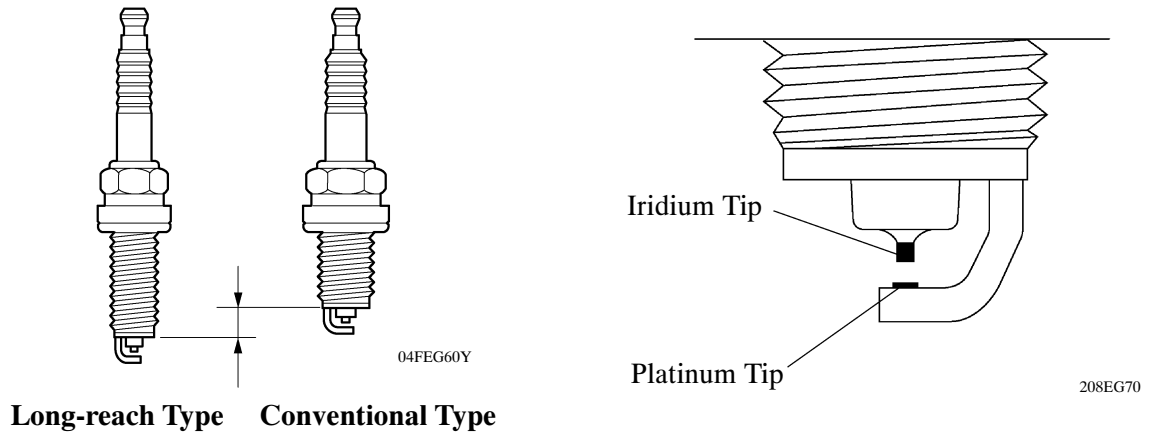

► **Specifications** ◀

Manufacture	Spark Plug Type	Plug Gap
DENSO	SK16HR11	1.0 – 1.1 mm (0.039 – 0.043 in.)

## 10. Charging System

### General

A compact and lightweight segment conductor type generator is used.

#### ► Specifications ◀

Type	SE0
Rated Voltage	12 V
Rated Output	100 A

### Segment Conductor Type Generator

- The segment conductor type generator generates a high amperage output in a highly efficient manner.
- This generator uses a joined segment conductor system, in which multiple segment conductors are welded together to the stator. Compared to the conventional winding system, the electrical resistance has been reduced due to the shape of the segment conductors, and their arrangement helps to make the generator more compact.

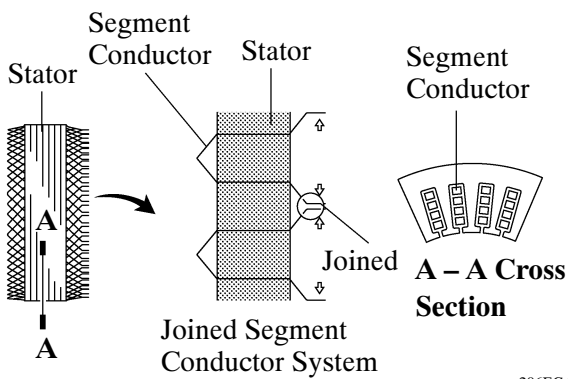

Segment Conductor Type Generator

206EG40

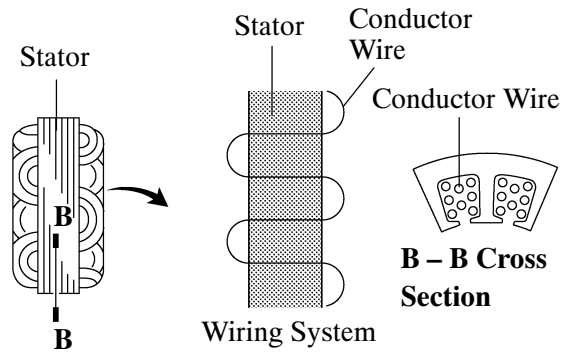

Conventional Type Generator

206EG41

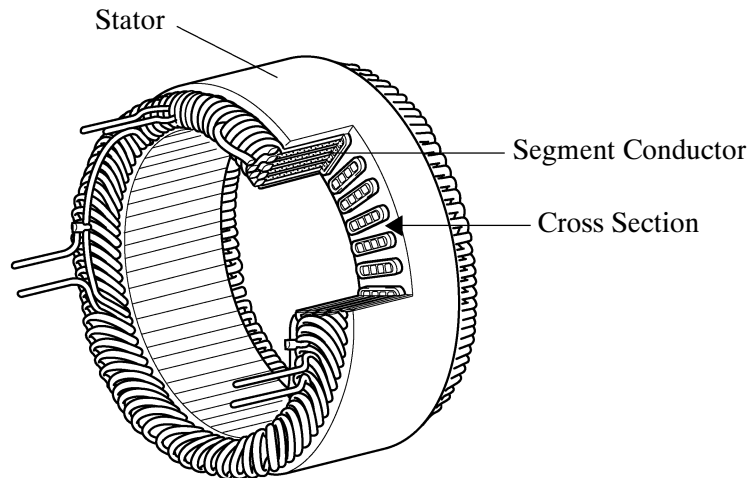

Stator of Segment Conductor Type Generator

206EG42

► Wiring Diagram ◀

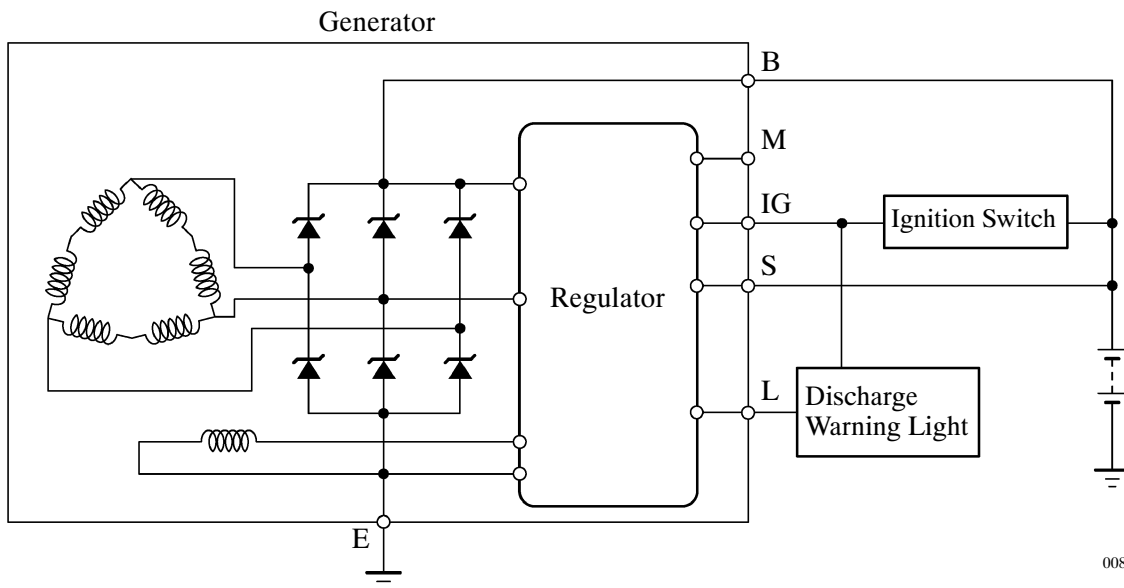



## 11. Starting System

### General

- A compact and lightweight PS (Planetary reduction-Segment conductor motor) type starter is used.
- Because the PS type starter contains an armature that uses square-shaped conductors, and its surface functions as a commutator, its output torque has been improved and its overall length has been reduced.
- In place of the field coil used in the conventional type starter, the PS type starter uses two types of permanent magnets: main magnets and interpolar magnets. The main magnets and interpolar magnets have been efficiently arranged to increase the magnetic flux and to shorten the length of the yoke.

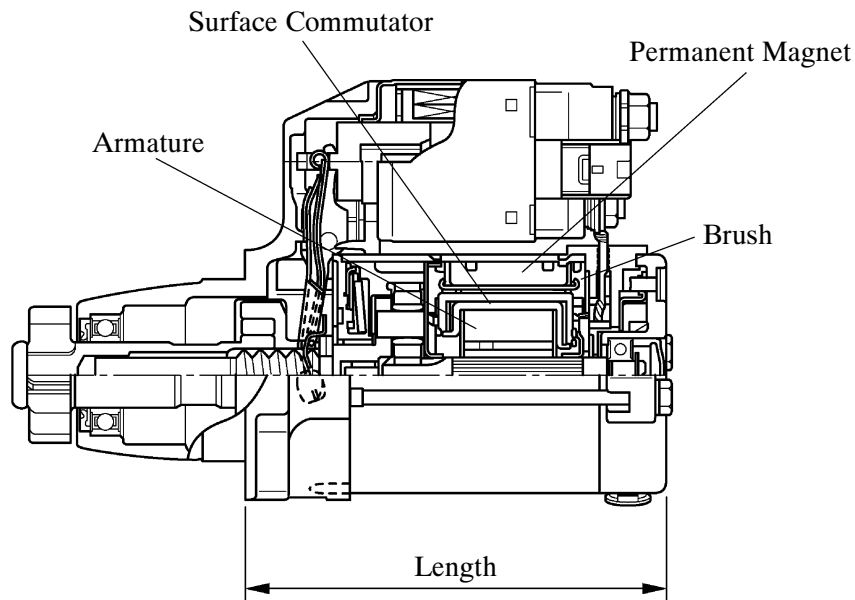

01NEG46Y

### ► Specifications ◀

Starter Type	PS Type
Rating Output	1.7 kW
Rating Voltage	12 V
Length* <sup>1</sup>	128.1 mm (5.04 in.)
Weight	2930 g (6.46 lb)
Rotational Direction* <sup>2</sup>	Counterclockwise

\*1: Length from the mounted area to the rear end of the starter

\*2: Viewed from pinion side

**Construction**

- Instead of constructing the armature coil with conventional type round-shaped conductor wires, the PS type starter uses square-shaped conductors. With this type of construction, the same conditions achieved by winding numerous round-shaped conductor wires can be achieved without increasing the mass. As a result, the output torque has been increased, and the armature coil has been made more compact.
- Because the surface of the square-shaped conductors used in the armature coil functions as a commutator, the overall length of the PS type starter has been shortened.

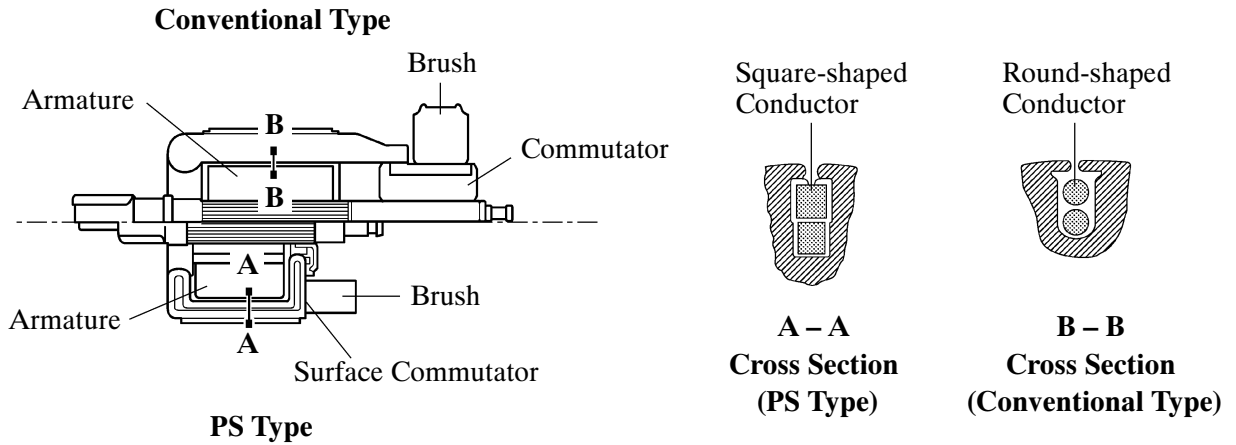

206EG20

- Instead of the field coils used in the conventional type starter, the PS type starter uses two types of permanent magnets: the main magnets and the interpolar magnets. The main and interpolar magnets are arranged alternately inside the yoke, allowing the magnetic flux generated between the main and interpolar magnets to be added to the magnetic flux generated by the main magnets. In addition to increasing the amount of magnetic flux, this construction shortens the overall length of the yoke.

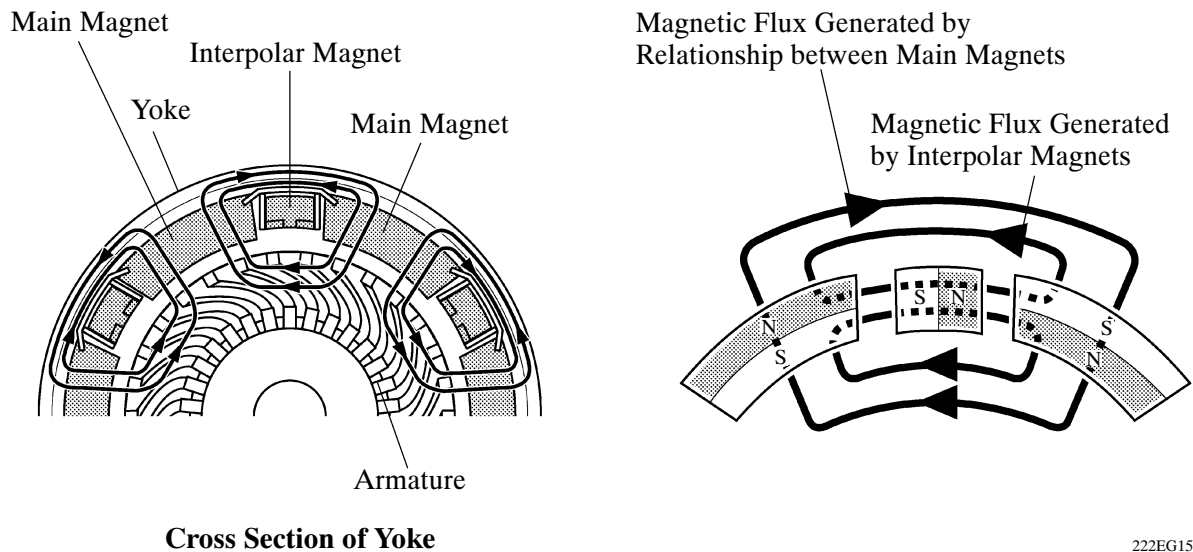

222EG15

## 12. Serpentine Belt Drive System

### General

- Accessory components are driven by a serpentine belt consisting of a single V-ribbed belt. It reduces the overall engine length, weight and the number of engine parts.
- An automatic tensioner eliminates the need for tension adjustment.

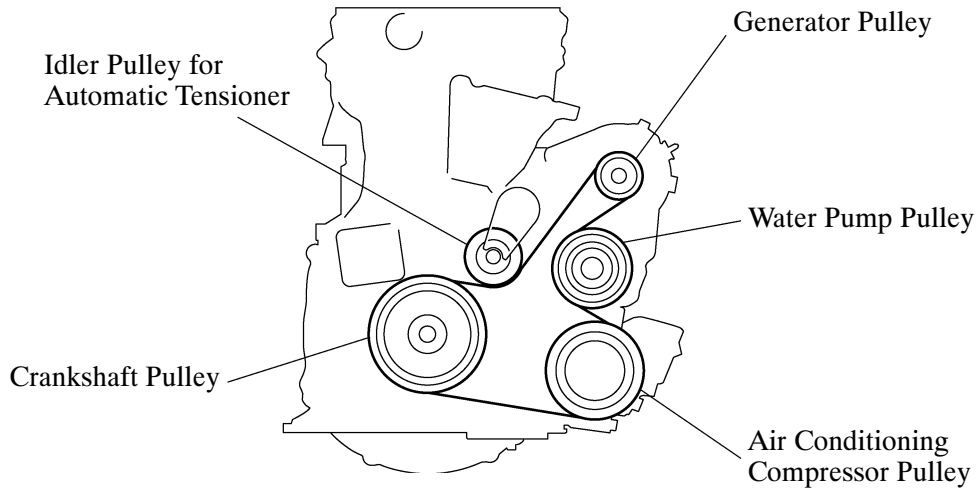

10SEG22Y

### Automatic Tensioner

The tension of the V-ribbed belt is properly maintained by the tension spring enclosed in the automatic tensioner.

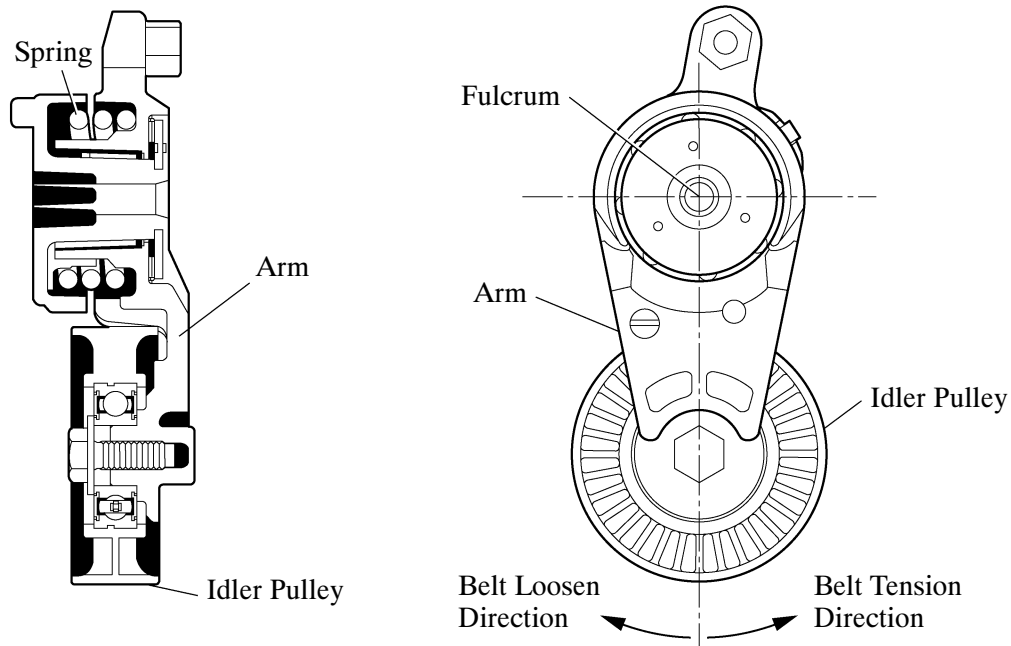

**Cross Section**

10SEG23Y

## 13. Engine Control System

### General

The engine control system for the 2AR-FE engine has the following systems:

System	Outline
SFI (Sequential Multiport Fuel Injection)	<ul style="list-style-type: none"> <li>● An L-type SFI system directly detects the intake air mass with a hot-wire type mass air flow meter.</li> <li>● The fuel injection system is a sequential multiport fuel injection system.</li> </ul>
ESA (Electronic Spark Advance)	Ignition timing is determined by the ECM based on signals from various sensors. The ECM corrects ignition timing in response to engine knocking.
ETCS-i (Electronic Throttle Control System-intelligent) [See page 67]	<p>Optimally controls the throttle valve opening in accordance with the amount of accelerator pedal effort and the condition of the engine and the vehicle.</p> <ul style="list-style-type: none"> <li>● A linkless-type is used, without an accelerator cable.</li> <li>● An accelerator pedal position sensor is provided on the accelerator pedal.</li> <li>● A non-contact type throttle position sensor and the accelerator pedal position sensor are used.</li> </ul>
Dual VVT-i (Variable Valve Timing-intelligent) System [See page 72]	Controls the intake and exhaust camshafts to an optimal valve timing in accordance with the engine condition.
ACIS (Acoustic Control Induction System) [See page 78]	The intake air passages are switched according to the engine speed and throttle valve opening angle to provide high performance in all speed ranges.
Tumble Control System [See page 81]	Controls fully closes the tumble control valve during cold start and cold running conditions to improve exhaust emissions while the engine is running cold.
Air-fuel Ratio Sensor and Oxygen Sensor Heater Control	Maintains the temperature of the air-fuel ratio sensor or oxygen sensor at an appropriate level to achieve accuracy of detection of the oxygen concentration in the exhaust gas.
Air Conditioning Cut-off Control	Maintains drivability by turning the air conditioning compressor ON or OFF in accordance with the engine condition.
Cooling Fan Control [See page 83]	Radiator cooling fan operation is controlled by signals from the ECM based on the engine coolant temperature sensor signal and the operating condition of the air conditioning.
Fuel Pump Control [See page 84]	<ul style="list-style-type: none"> <li>● Fuel pump operation is controlled by a signal from the ECM.</li> <li>● The fuel pump is stopped when the SRS airbags are deployed.</li> </ul>

(Continued)

System	Outline
Starter Control (Cranking Hold Function)* [See page 85]	Once the engine switch is pushed, this control continues to operate the starter until the engine is started.
Evaporative Emission Control [See page 87]	The ECM controls the purge flow of evaporative emissions (HC) in the canister in accordance with engine conditions.
	Approximately five hours after the ignition switch has been turned OFF, the ECM operates the canister pump module to detect any evaporative emission leakage occurring in the EVAP (evaporative emission) control system through changes in the 0.02 in. leak pressure.
Engine Immobilizer	Prohibits fuel delivery and ignition if an attempt is made to start the engine with an invalid ignition key.
Diagnosis [See page 100]	When the ECM detects a malfunction, it diagnoses and memorizes the failed section.
Fail-safe [See page 100]	When the ECM detects a malfunction, it stops or controls the engine according to the data already stored in memory.

\*: Models with smart key system

**Construction**

The configuration of the engine control system in the 2AR-FE engine is shown in the following chart:

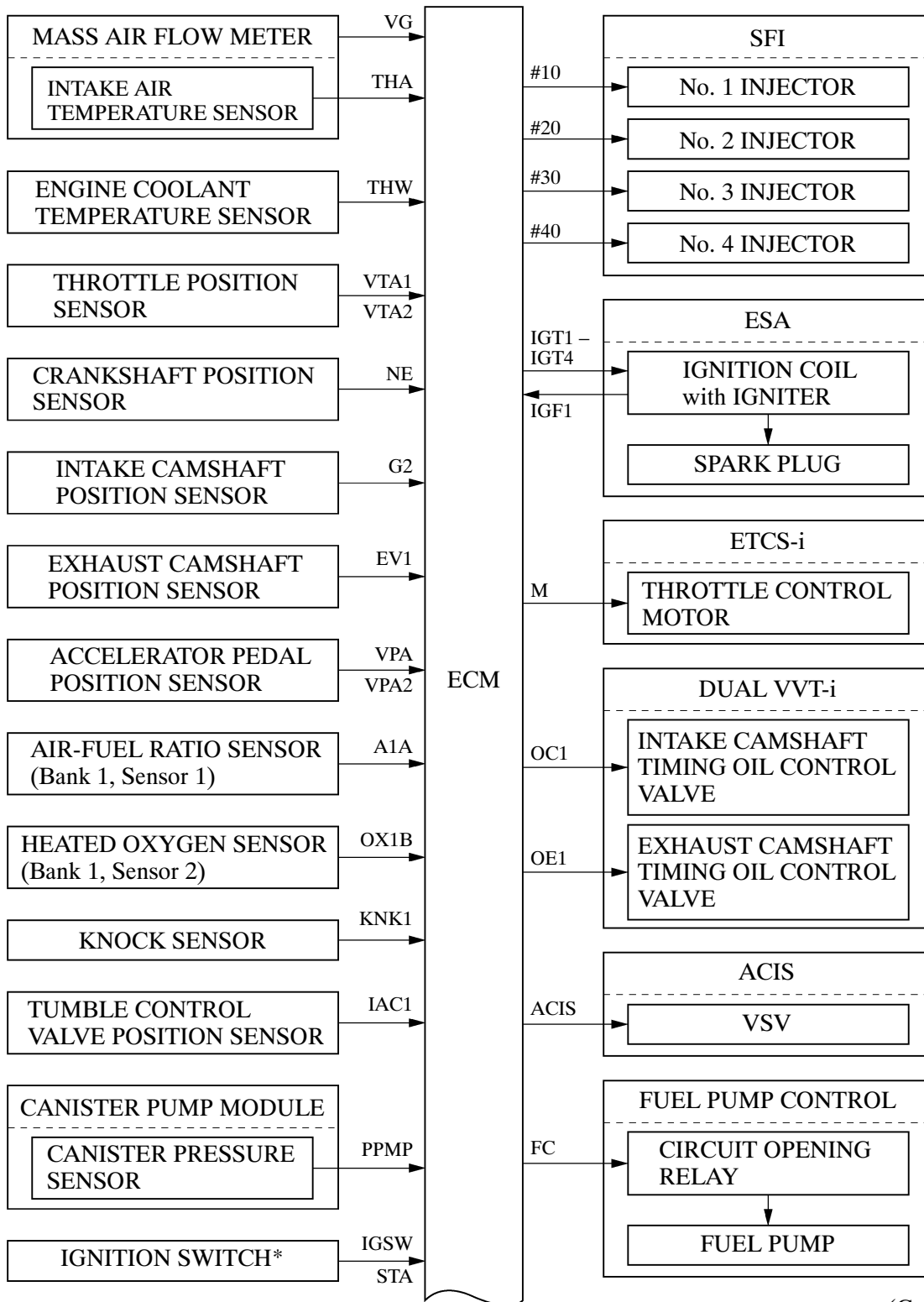

(Continued)

\*: Except models with smart key system

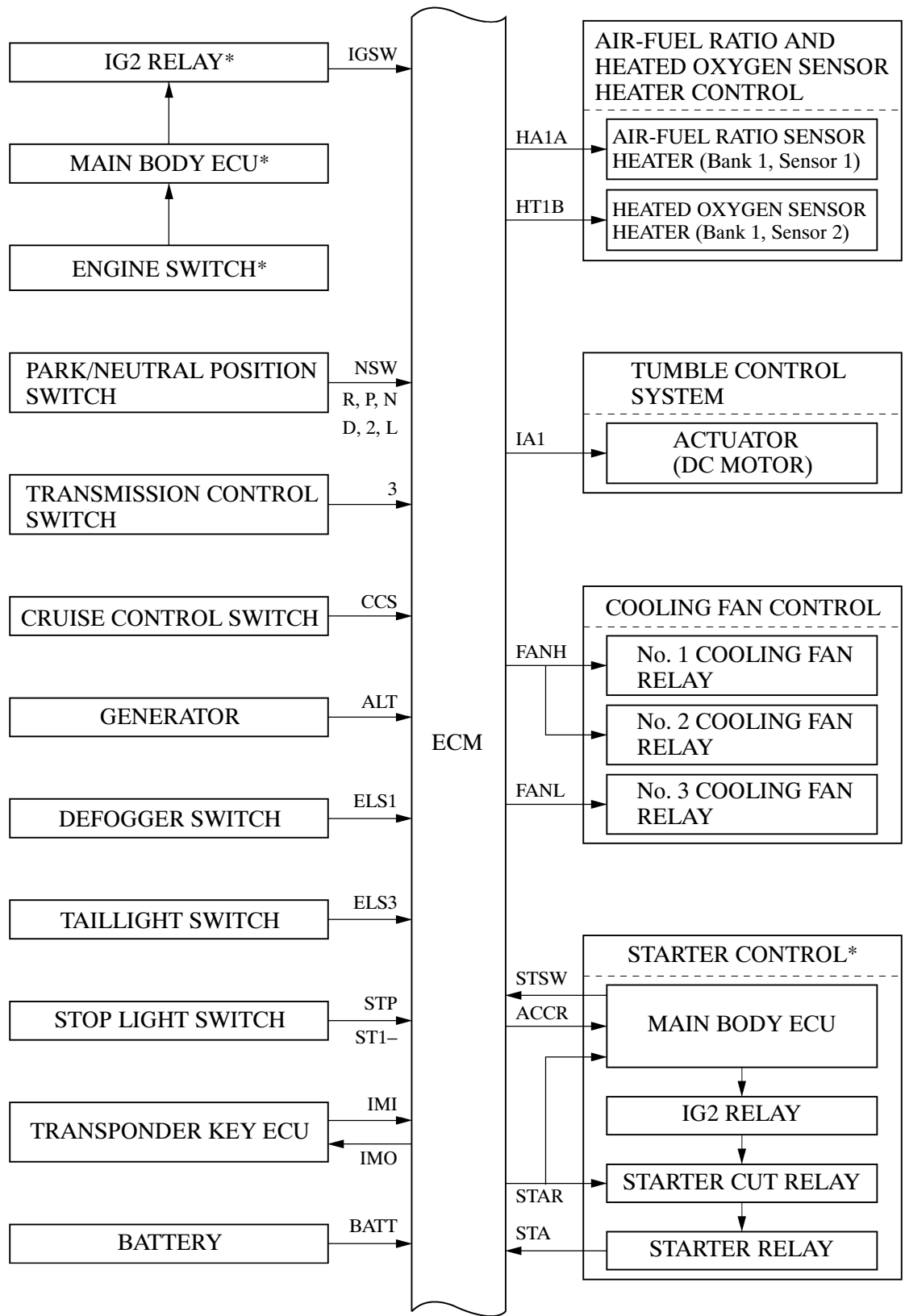

(Continued)

\*: Models with smart key system

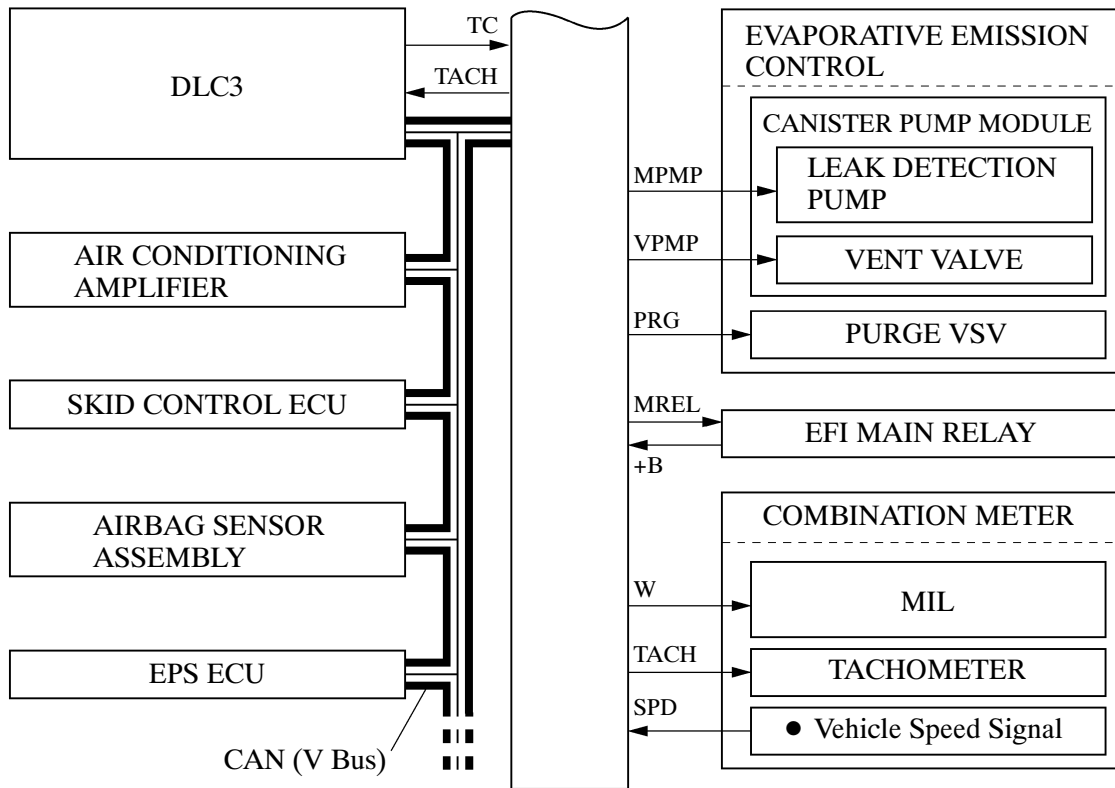

10SEG07Y



**Engine Control System Diagram**

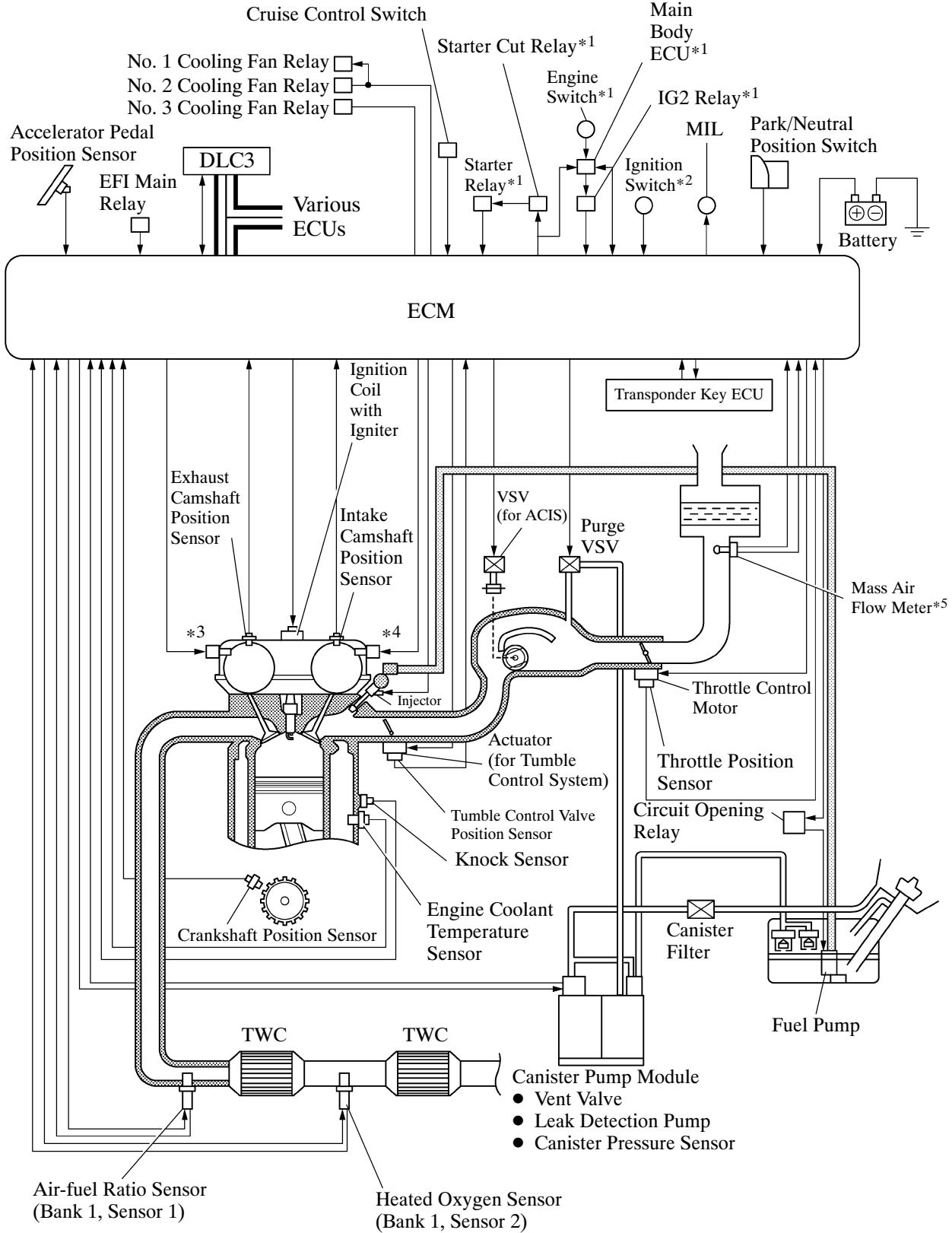

- \*1: Models with smart key system
- \*2: Except models with smart key system
- \*3: Exhaust Camshaft Timing Oil Control Valve
- \*4: Intake Camshaft Timing Oil Control Valve
- \*5: Built-in intake air temperature sensor

**Layout of Main Components**

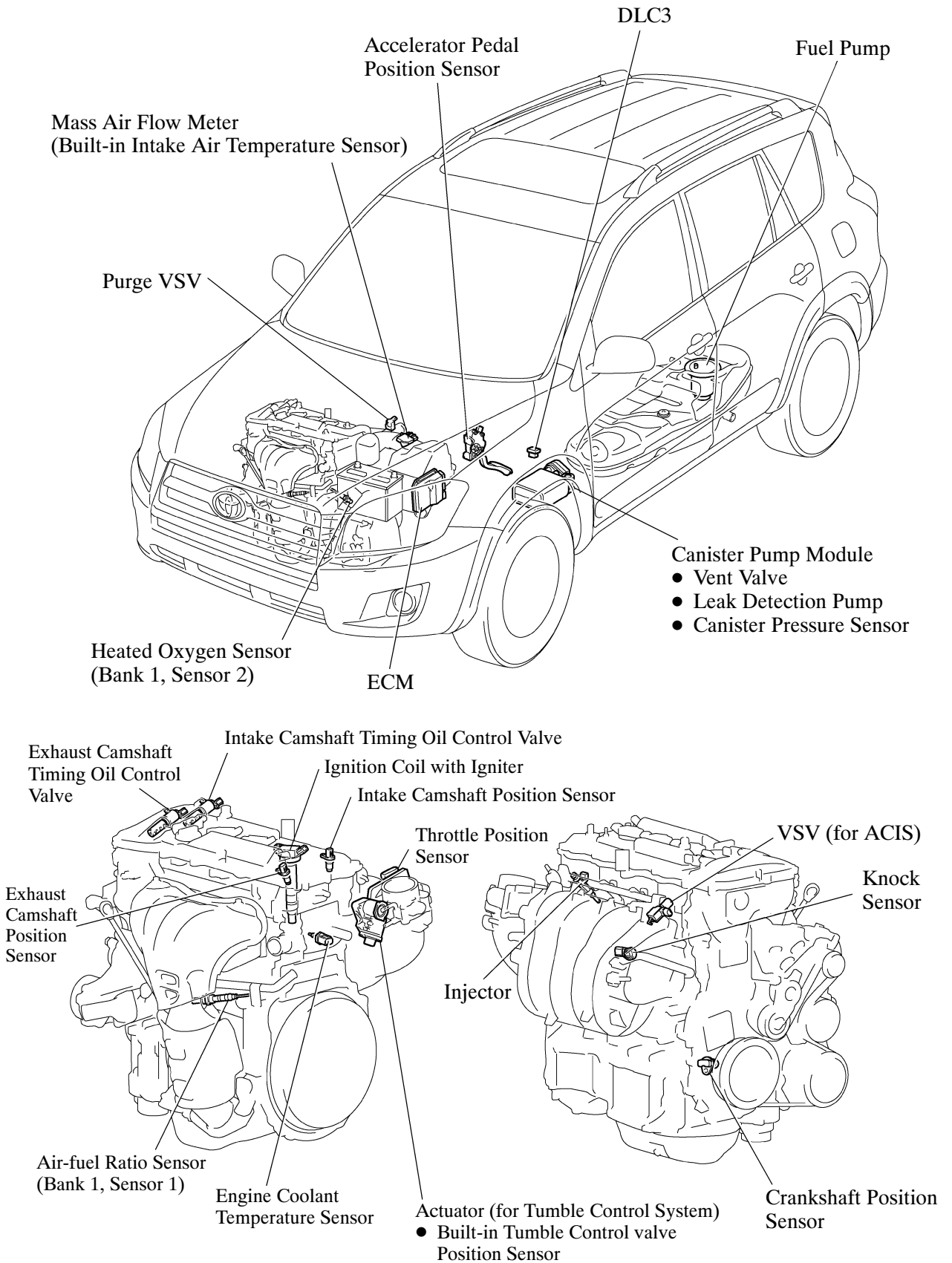

## Main Components of Engine Control System

### 1) General

The main components of the 2AR-FE engine control system are as follows:

Components	Outline	Quantity	Function
ECM	32-bit CPU	1	The ECM optimally controls the SFI, ESA, and ISC to suit the operating conditions of the engine in accordance with the signals provided by the sensors.
Air-fuel Ratio Sensor (Bank 1, Sensor 1) [See page 58]	Type with Heater (Planar Type)	1	This sensor detects the oxygen concentration in the exhaust emission by measuring the electromotive force generated in the sensor itself.
Heated Oxygen Sensor (Bank 1, Sensor 2) [See page 58]	Type with Heater (Cup Type)	1	
Mass Air Flow Meter [See page 59]	Hot-wire Type	1	This sensor has a built-in hot-wire to directly detect the intake air mass.
Intake Air Temperature Sensor [See page 59]	Thermistor Type	1	<ul style="list-style-type: none"> <li>● This sensor detects the intake air temperature by means of an internal thermistor.</li> <li>● This sensor is integrated in the mass air flow meter.</li> </ul>
Crankshaft Position Sensor [See page 60]	Pick-up Coil Type (Rotor Teeth/36 - 2)	1	This sensor detects the engine speed and performs the cylinder identification.
Camshaft Position Sensor [See page 60]	MRE (Magnetic Resistance Element) Type (Rotor Teeth/3)	2	This sensor performs the cylinder identification.
Throttle Position Sensor [See page 62]	Non-contact Type	1	This sensor detects the throttle valve opening angle.
Accelerator Pedal Position Sensor [See page 63]	Non-contact Type	1	This sensor detects the amount of pedal effort applied to the accelerator pedal.
Tumble Control Valve Position Sensor [See page 64]	Non-contact Type	1	This sensor detects the tumble control valve opening angle.
Knock Sensor [See page 65]	Built-in Piezoelectric Element Type (Flat Type)	1	This sensor detects an occurrence of the engine knocking indirectly from the vibration of the cylinder block caused by the occurrence of engine knocking.

(Continued)

---

Components	Outline	Quantity	Function
Engine Coolant Temperature Sensor	Thermistor Type	1	This sensor detects the engine coolant temperature by means of an internal thermistor.
Injector	12-hole Type	4	The injector is an electromagnetically-operated nozzle which injects fuel in accordance with the signals from the ECM.

2) Air-fuel Ratio Sensor and Heated Oxygen Sensor

a. General

- The air-fuel ratio sensor and heated oxygen sensor differ in output characteristics.
- Approximately 0.4 V is constantly applied to the air-fuel ratio sensor, which outputs an amperage that varies in accordance with the oxygen concentration in the exhaust emission. The ECM converts the changes in the output amperage into voltage in order to linearly detect the present air-fuel ratio. The air-fuel ratio sensor data is read out by the Techstream.
- The output voltage of the heated oxygen sensor changes in accordance with the oxygen concentration in the exhaust emission. The ECM uses this output voltage to determine whether the present air-fuel ratio is richer or leaner than the stoichiometric air-fuel ratio.

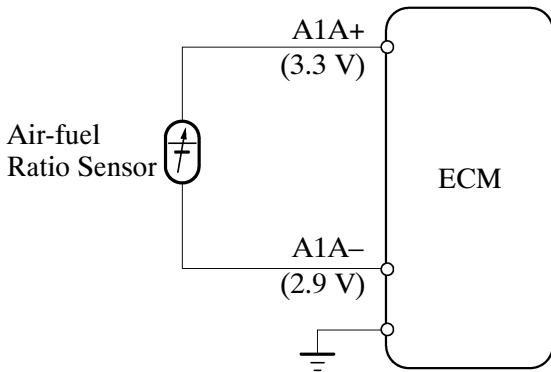

Air-fuel Ratio Sensor Circuit

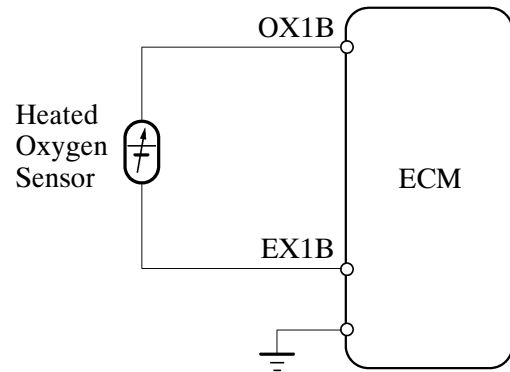

00REG21Y

Heated Oxygen Sensor

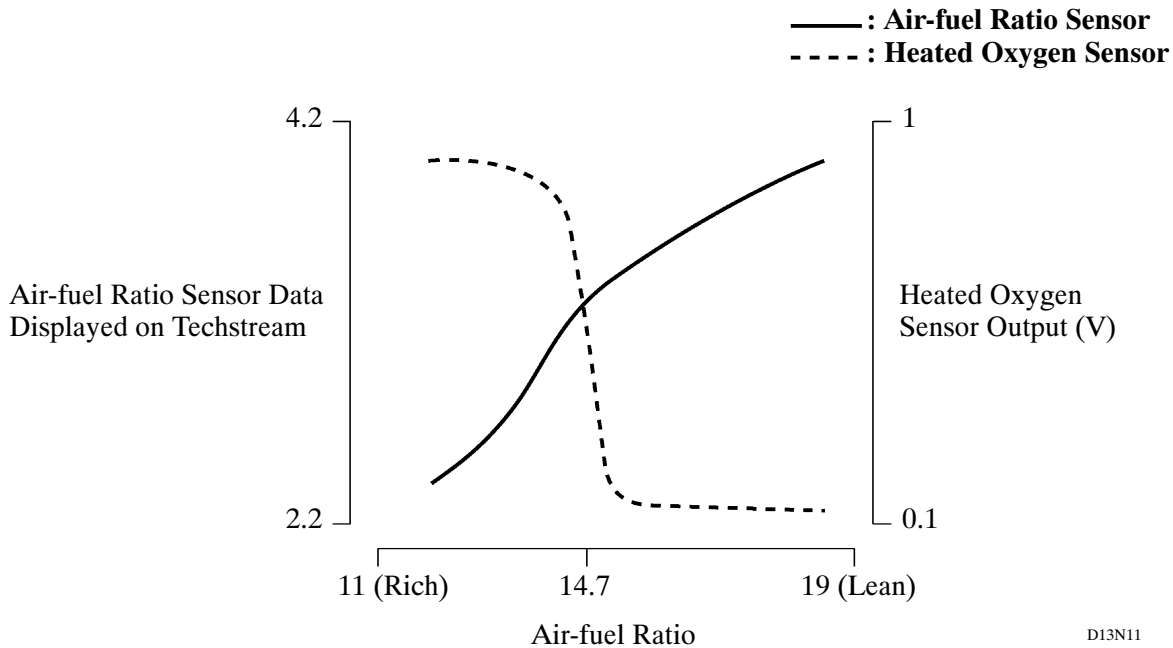

D13N11

**b. Construction**

- The basic construction of the air-fuel ratio sensor and heated oxygen sensor is the same. However, they are divided into the cup type and the planar type, according to the different types of heater construction that are used.
- The cup type heated oxygen sensor contains a sensor element that surrounds the heater.
- The planar type air-fuel ratio sensor uses alumina, which excels in heat conductivity and insulation, to integrate a sensor element with the heater, thus achieving the excellent warm-up performance of the sensor.

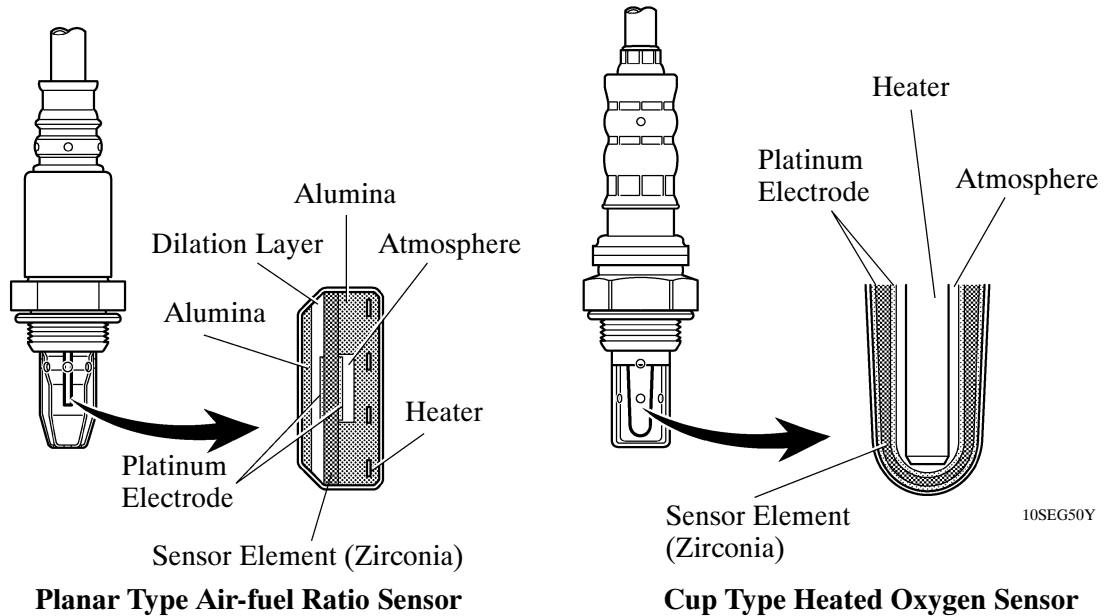

► **Warm-up Specification** ◀

Sensor Type	Planar Type	Cup Type
Warm-up Time	Approx. 10 sec.	Approx. 30 sec.

**3) Mass Air Flow Meter**

- The compact and lightweight mass air flow meter, which is a plug-in type, allows a portion of the intake air to flow through the detection area. By directly measuring the mass and the flow rate of the intake air, detection precision is ensured and intake air resistance is reduced.
- This mass air flow meter has a built-in intake air temperature sensor.

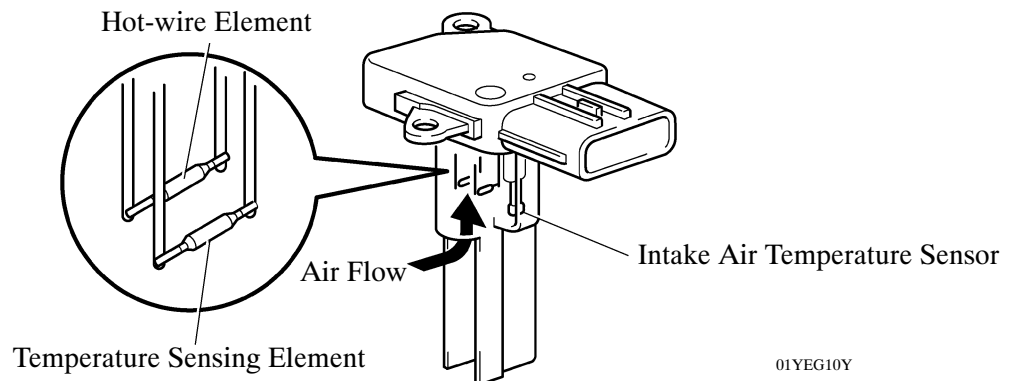

### 4) Crankshaft and Camshaft Position Sensors

#### a. General

- The pick-up coil type crankshaft position sensor is used. The timing rotor of the crankshaft consists of 34 teeth, with 2 teeth missing. The crankshaft position sensor outputs the crankshaft rotation signals every 10°, and the missing teeth are used to determine the top dead center.
- The MRE (Magnetic Resistance Element) type intake and exhaust camshaft position sensors are used. To detect the camshaft position, each timing rotor on the intake and exhaust camshafts is used to generate 3 (3 high output, 3 low output) pulses for every 2 revolutions of the crankshaft.

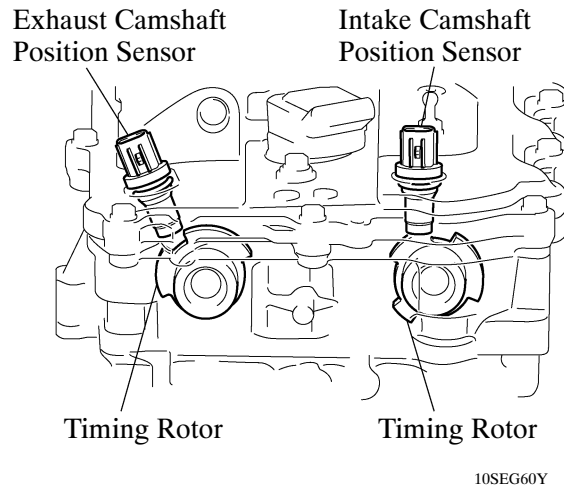
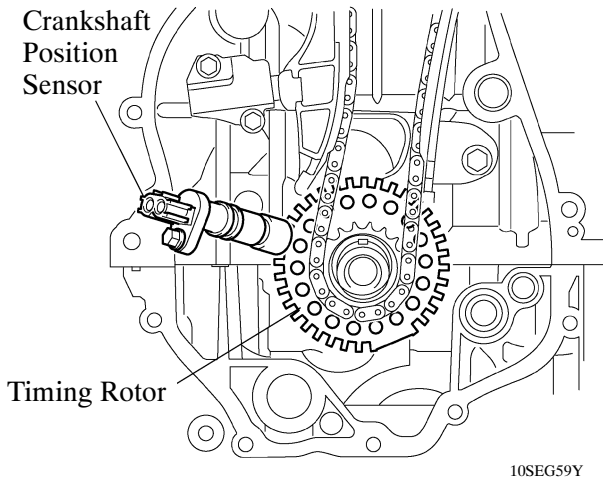

#### ► Sensor Output Waveforms ◀

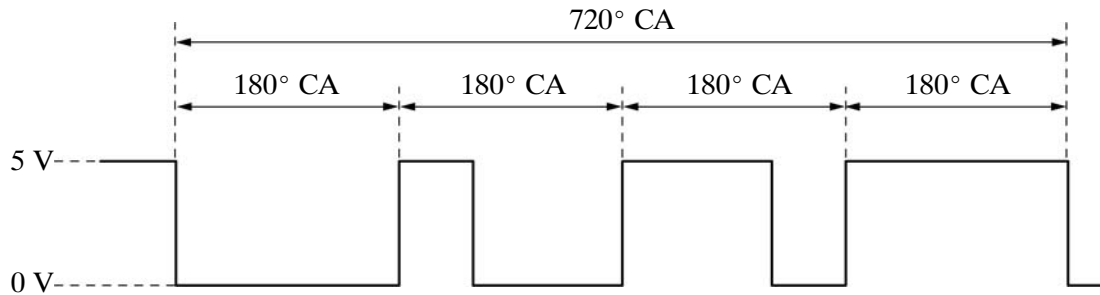

Camshaft Position Sensor Output Waveform

10SEG57I

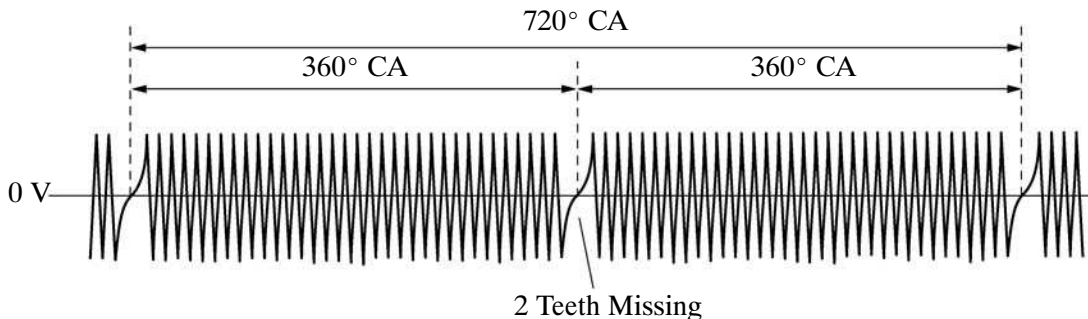

Crankshaft Position Sensor Output Waveform

10SEG58I

**b. MRE Type Camshaft Position Sensor**

- The MRE type camshaft position sensor consists of an MRE, a magnet and a sensor. The direction of the magnetic field changes due to the different shapes (protruded and non-protruded portions) of the timing rotor, which passes by the sensor. As a result, the resistance of the MRE changes, and the output voltage to the ECM changes to high or low. The ECM detects the camshaft position based on this output voltage.
- The differences between the MRE type camshaft position sensor and the pick-up coil camshaft position sensor used on the conventional model are as follows:

Item	Sensor Type	
	MRE	Pick-up Coil
Signal Output	Constant digital output starts from low engine speeds.	Analog output changes with the engine speed.
Camshaft Position Detection	Detection is made by comparing the NE signals with the Hi/Lo output switch timing due to the protruded/non-protruded portions of the timing rotor, or made based on the number of the input NE signals during Hi/Lo outputs.	Detection is made by comparing the NE signals with the change of waveform that is output when the protruded portion of the timing rotor passes.

► **Wiring Diagram** ◀

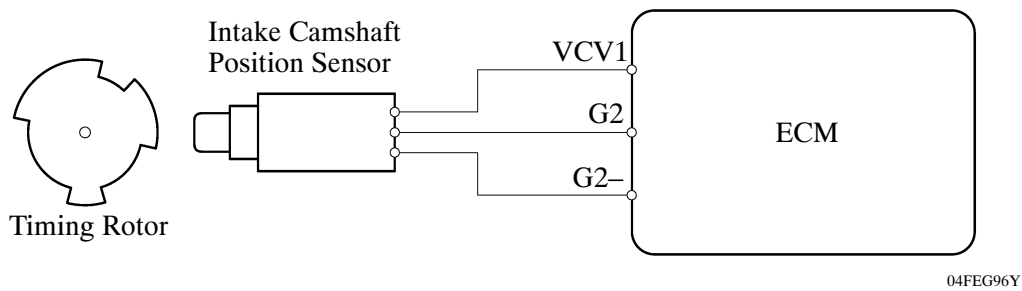

► **MRE Type and Pick-up Coil Type Output Waveform Image Comparison** ◀

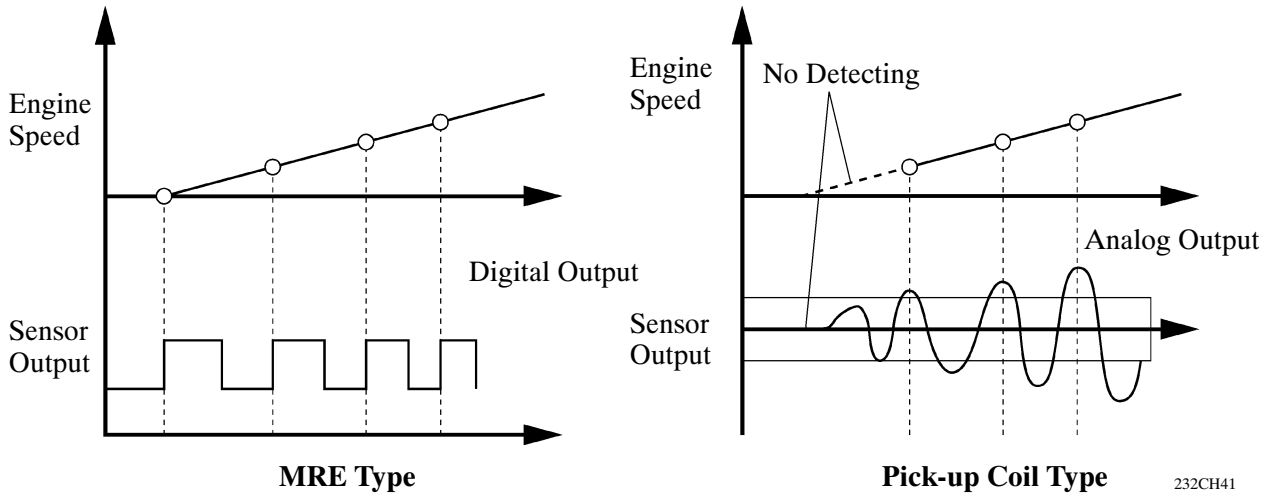



5) Throttle Position Sensor

The throttle position sensor is mounted on the throttle body to detect the opening angle of the throttle valve. The throttle position sensor converts the magnetic flux density that changes when the magnetic yoke (located on the same axis as the throttle shaft) rotates around the Hall IC into electric signals to operate the throttle control motor.

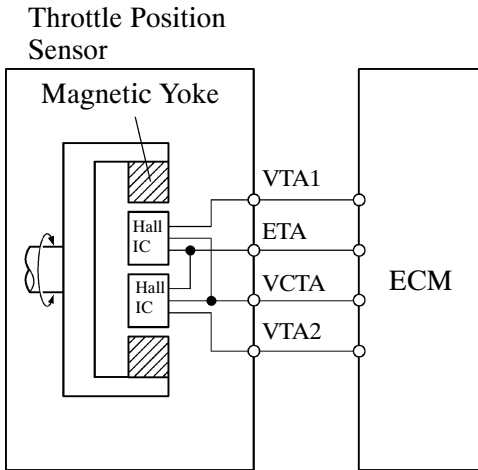
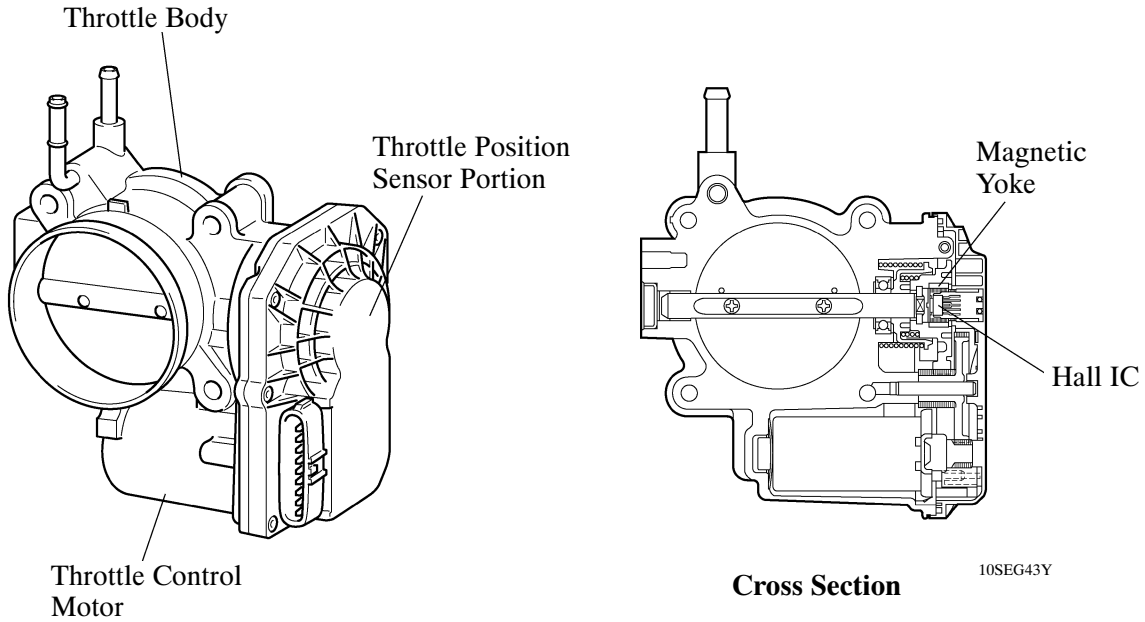

230LX12

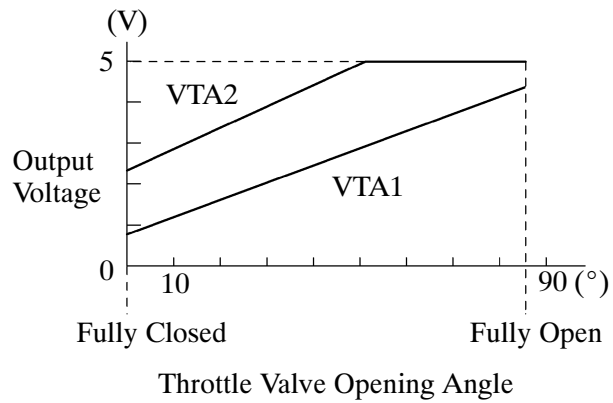

238EG79

**Service Tip**

The inspection method differs from the conventional contact type throttle position sensor because this non-contact type sensor uses a Hall IC.

For details, refer to the 2009 RAV4 Repair Manual (Pub. No. RM10S0U).

**6) Accelerator Pedal Position Sensor**

The non-contact type accelerator pedal position sensor uses a Hall IC.

- The magnetic yoke that is mounted at the accelerator pedal arm rotates around the Hall IC in accordance with the amount of effort that is applied to the accelerator pedal. The Hall IC converts the changes in the magnetic flux at that time into electrical signals, and outputs them as accelerator pedal effort to the ECM.
- The Hall IC contains circuits for the main and sub signals. It converts the accelerator pedal depressed angles into electric signals with two differing characteristics and outputs them to the ECM.

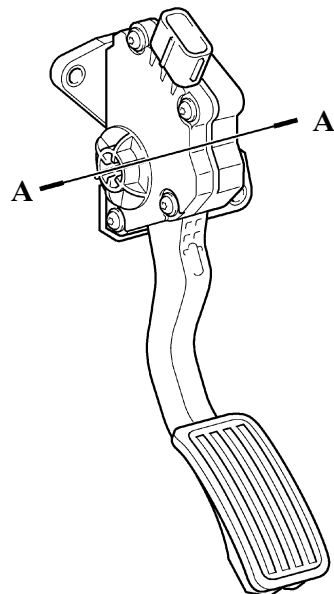

**Internal Construction**

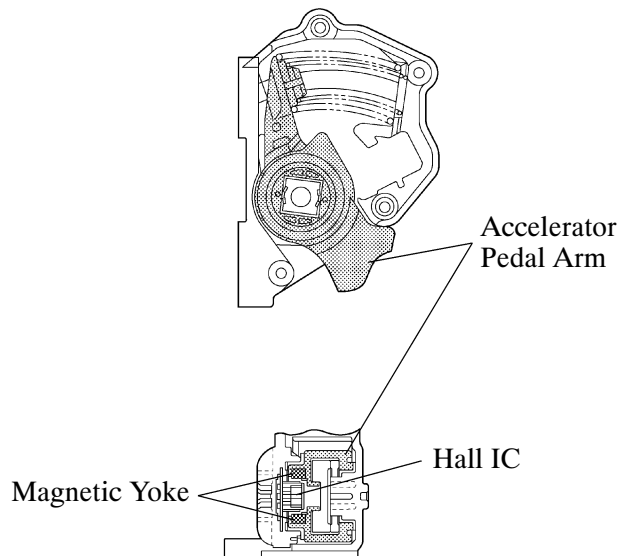

00SEG39Y

**A – A Cross Section**

Accelerator Pedal Position Sensor

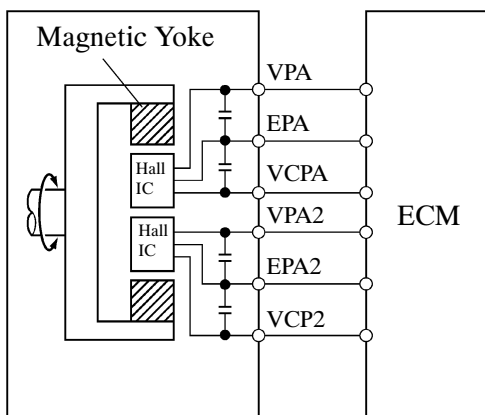

228TU24

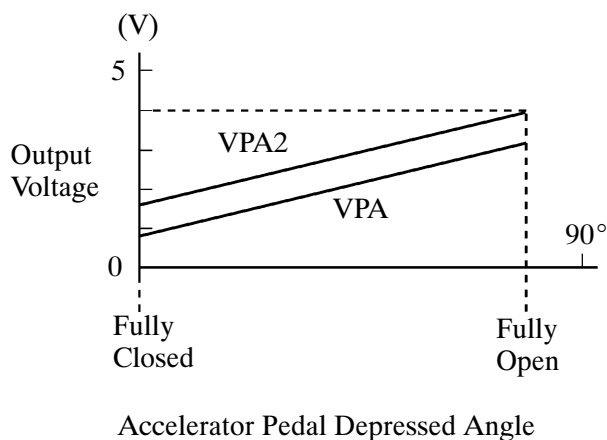

228TU25

**Service Tip**

The inspection method differs from the conventional contact type accelerator pedal position sensor because this non-contact type sensor uses a Hall IC. For details, refer to the 2009 RAV4 Repair Manual (Pub. No. RM10S0U).

**7) Tumble Control Valve Position Sensor**

The non-contact type tumble control valve position sensor uses a Hall IC.

It detects the tumble control valve opening angle.

The sensor converts the magnetic flux density that changes when the magnetic yoke (located on the same axis as the tumble control valve shaft) rotates around the Hall IC into electric signals and sends them to ECM.

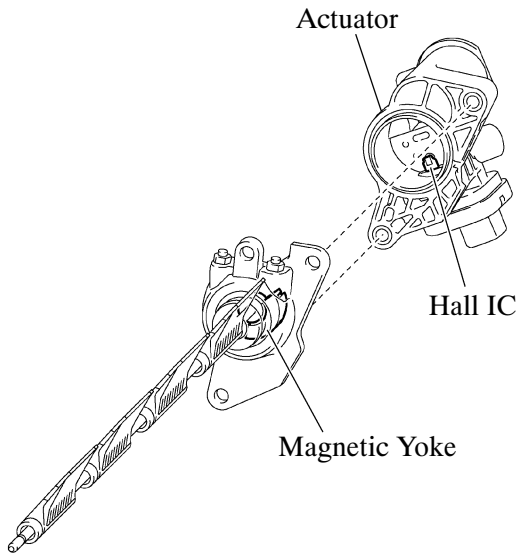

10SEG51Y

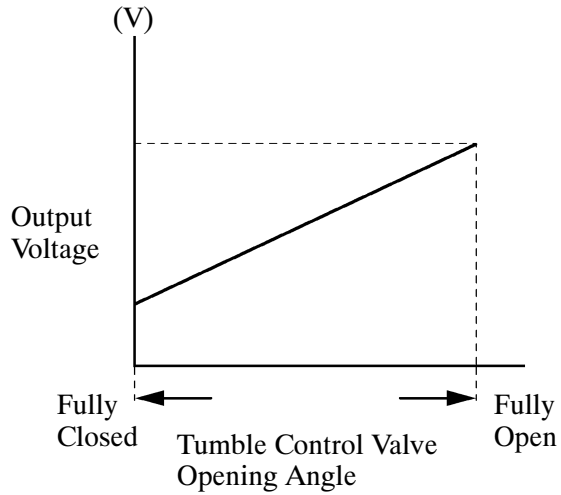

10SEG52Y

**► System Diagram ◀**

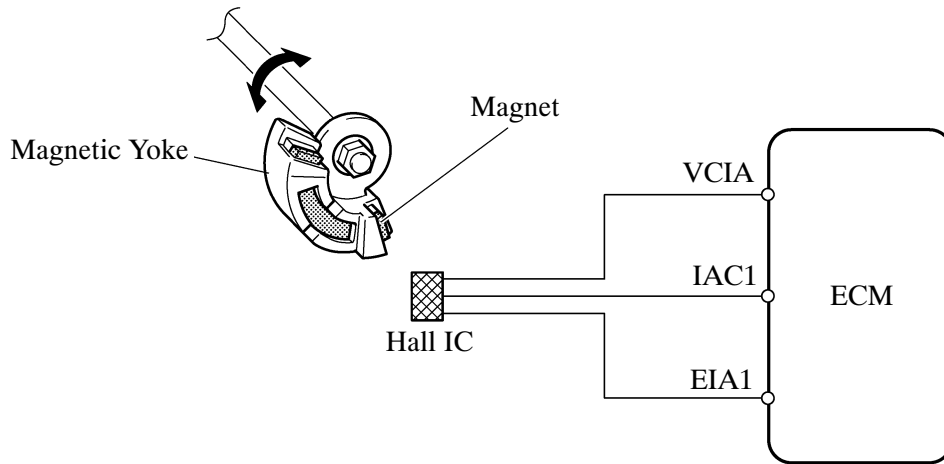

10SEG53Y

**8) Knock Sensor (Flat Type)**

**a. General**

In the conventional type knock sensor (resonant type), a vibration plate which has the same resonance point as the knocking frequency of the engine is built in and can detect the vibration in this frequency band. On the other hand, a flat type knock sensor (non-resonant type) has the ability to detect vibration in a wider frequency band from about 6 kHz to 15 kHz, and has the following features:

- The engine knocking frequency will change a bit depending on the engine speed. The flat type knock sensor can detect the vibration even when the engine knocking frequency is changed. Thus the vibration detection ability is increased compared to the conventional type knock sensor, and a more precise ignition timing control is possible.

--- : Conventional Type  
 — : Flat Type

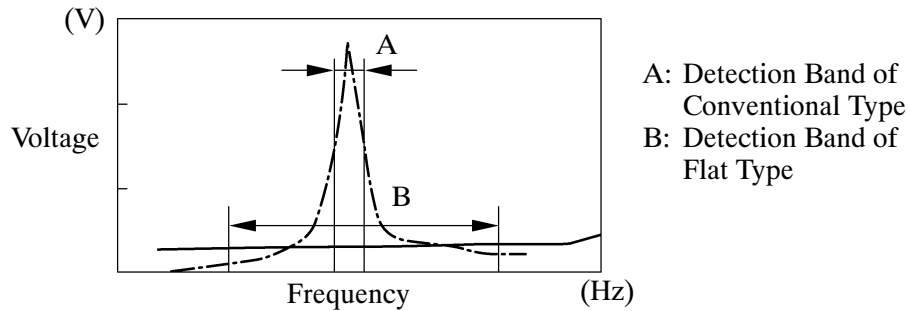

**Characteristic of Knock Sensor**

214CE04

**b. Construction**

- The flat type knock sensor is installed on the engine through the stud bolt installed on the cylinder block. For this reason, a hole for the stud bolt runs through the center of the sensor.
- Inside the sensor, a steel weight is located on the upper portion and a piezoelectric element is located under the weight through the insulator.
- The open/short circuit detection resistor is integrated.

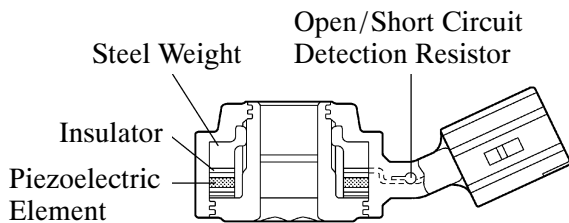

214CE01

**Flat Type Knock Sensor  
 (Non-resonant Type)**

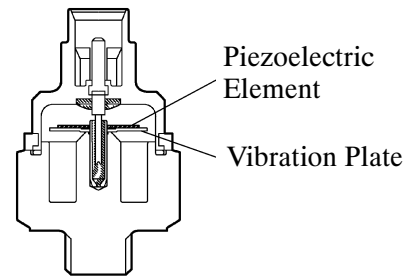

214CE02

**Conventional Type Knock Sensor  
 (Resonant Type)**

### c. Operation

The knocking vibration is transmitted to the steel weight and its inertia applies pressure to the piezoelectric element. The action generates electromotive force.

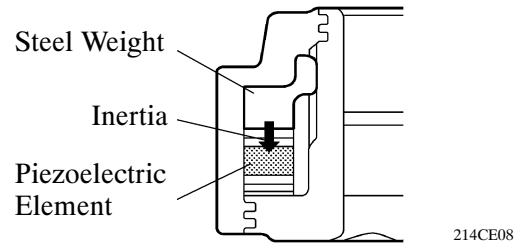

### d. Open/Short Circuit Detection Resistor

While the ignition is ON, the open/short circuit detection resistor in the knock sensor and the resistor in the ECM keep constant the voltage at the terminal KNK1 of engine.

An IC (Integrated Circuit) in the ECM is always monitoring the voltage of the terminal KNK1. If the open/short circuit occurs between the knock sensor and the ECM, the voltage of the terminal KNK1 will change and the ECM detects the open/short circuit and stores DTC (Diagnostic Trouble Code).

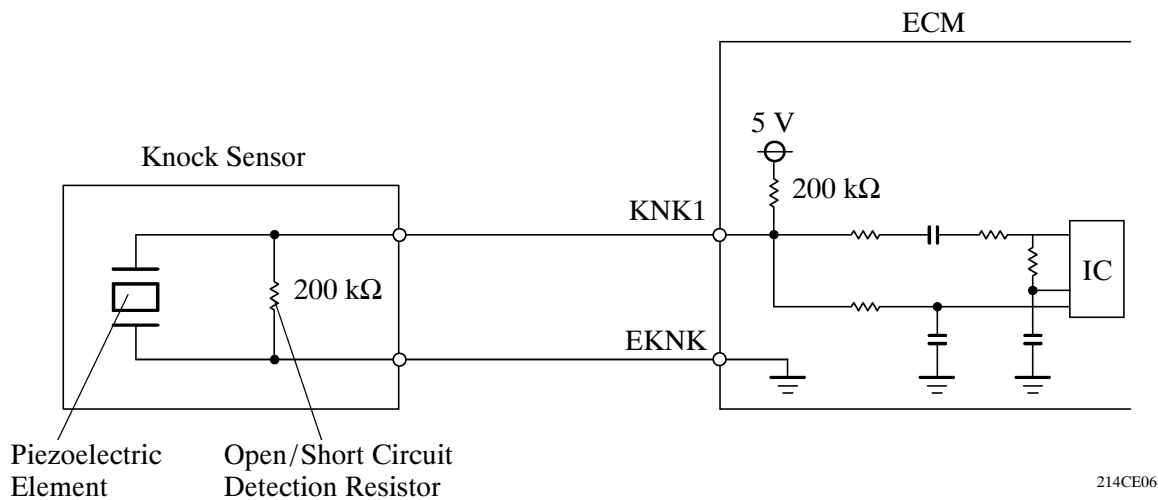

#### Service Tip

- In accordance with the use of an open/short circuit detection resistor, the inspection method for the sensor has been changed. For details, refer to the 2009 RAV4 Repair Manual (Pub. No. RM10S0U).
- To prevent water accumulation in the connector, make sure to install the flat type knock sensor in the position shown in the following illustration:

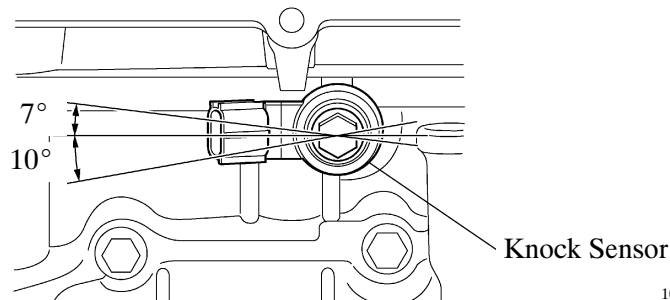

## ETCS-i (Electronic Throttle Control System-intelligent)

### 1) General

- The ETCS-i is used, providing excellent throttle control in all the operating ranges. In the 2AR-FE engine, the accelerator cable has been discontinued, and an accelerator pedal position sensor has been provided on the accelerator pedal.
- In the conventional throttle body, the throttle valve opening is determined by the amount of the accelerator pedal effort. In contrast, the ETCS-i uses the ECM to calculate the optimal throttle valve opening that is appropriate for the respective driving condition and uses a throttle control motor to control the opening.
- The ETCS-i controls the IAC (Idle Air Control) system, TRAC (Traction Control), VSC (Vehicle Stability Control) system and cruise control system.
- In case of an abnormal condition, this system switches to the limp mode.

### ► System Diagram ◀

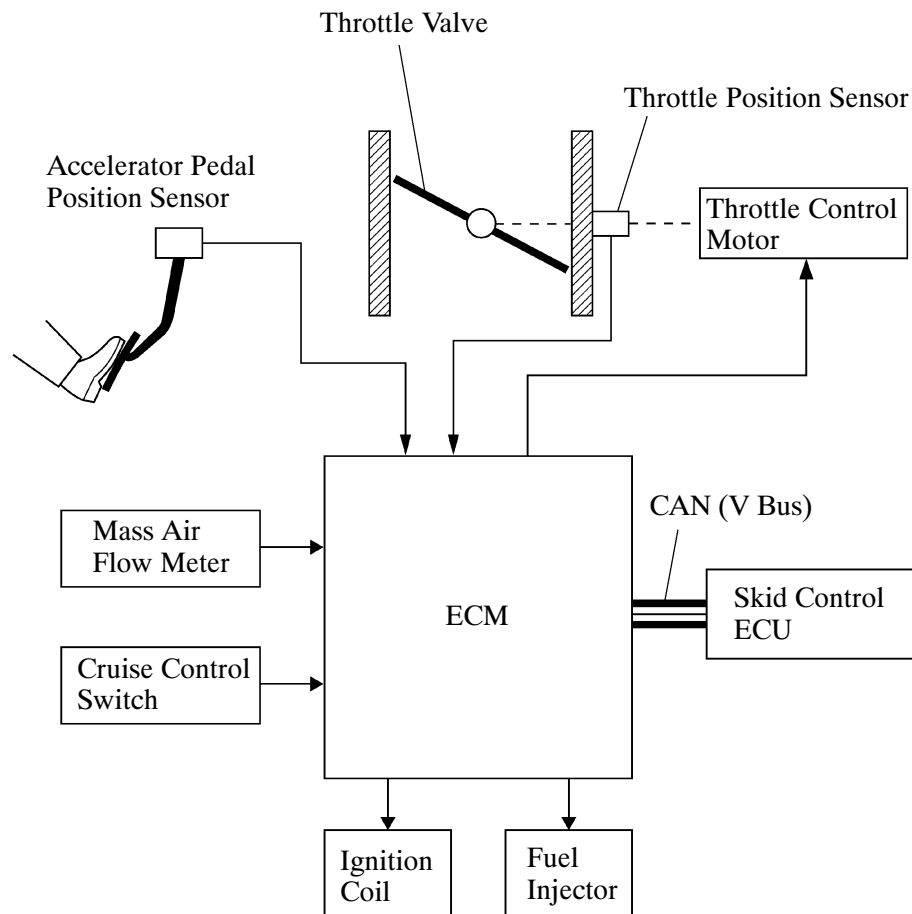

10SEG44I

## 2) Construction

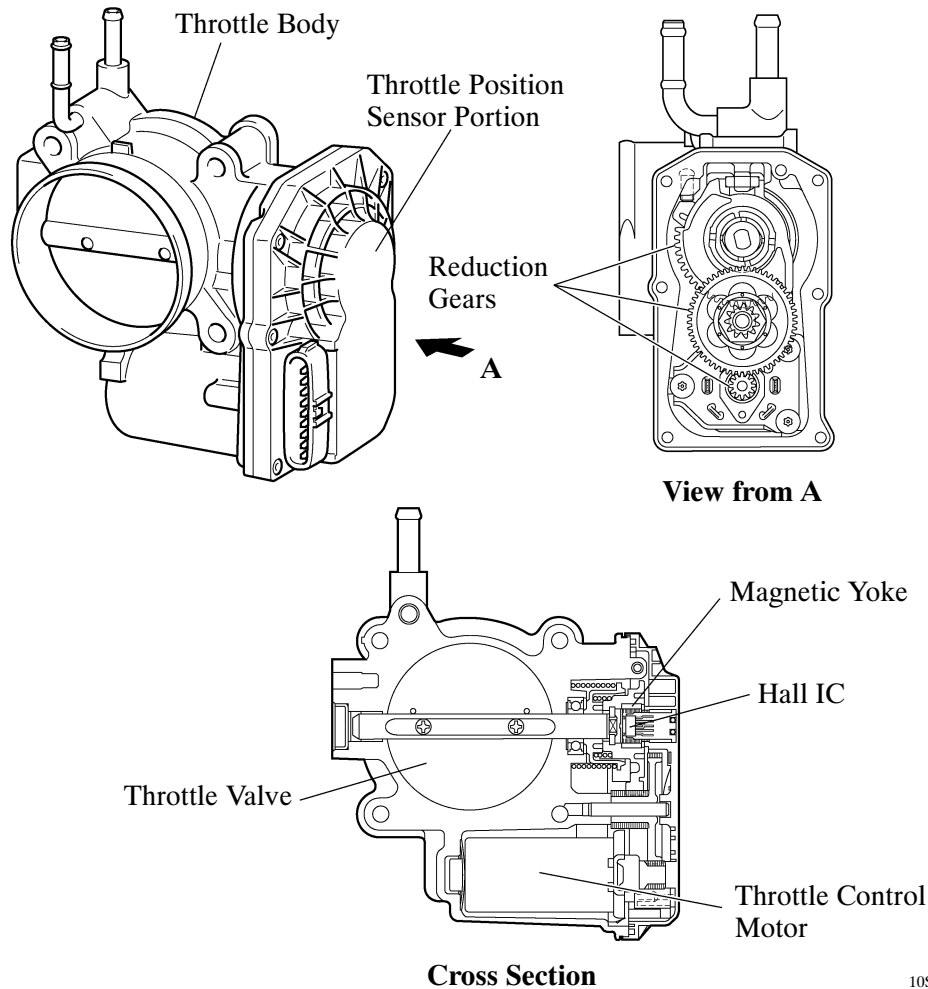

10SEG45Y

### a. Throttle Position Sensor

The throttle position sensor is mounted on the throttle body, to detect the opening angle of the throttle valve.

### b. Throttle Control Motor

A DC motor with excellent response and minimal power consumption is used for the throttle control motor. The ECM performs the duty cycle control of the direction and the amperage of the current that flows to the throttle control motor in order to regulate the opening of the throttle valve.

## 3) Operation

### a. General

The ECM drives the throttle control motor by determining the target throttle valve opening in accordance with the respective operating condition.

- Non-linear Control
- Idle Air Control
- TRAC Throttle Control
- VSC Coordination Control
- Cruise Control

### b. Normal Throttle Control (Non-linear Control)

This controls the throttle to an optimal throttle valve opening that is appropriate for the driving condition such as the amount of the accelerator pedal effort and the engine speed in order to achieve excellent throttle control and comfort in all operating ranges.

#### ► Control Examples During Acceleration and Deceleration ◀

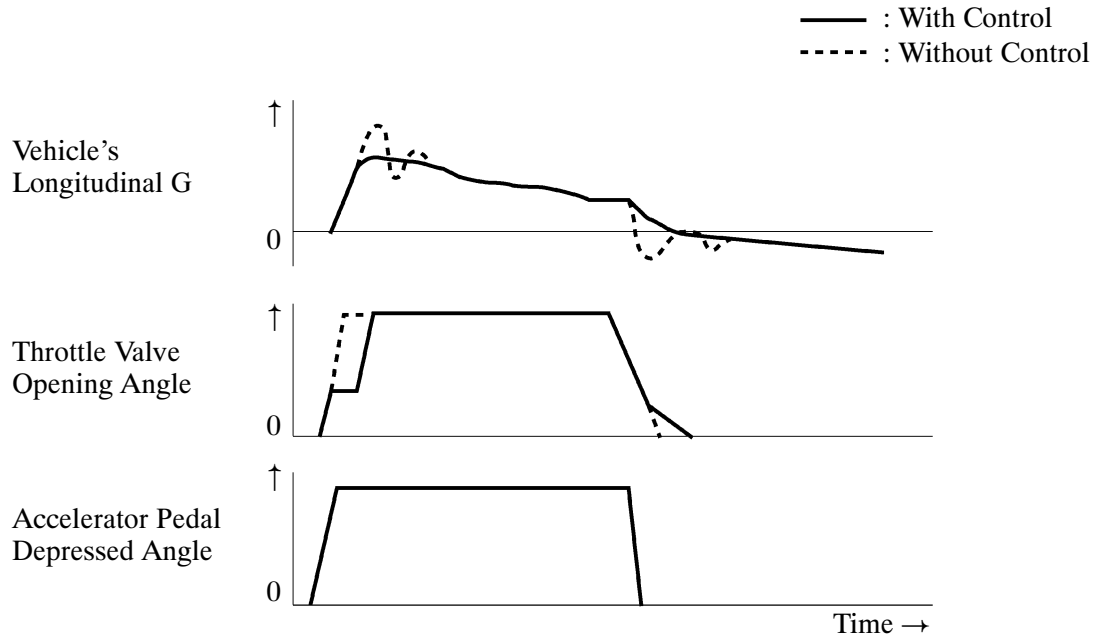

005EG13Y

### c. Idle Air Control

The ECM controls the throttle valve in order to constantly maintain an ideal idle speed.

### d. TRAC Throttle Control

As part of the TRAC system, the throttle valve is closed by a demand signal from the skid control ECU if an excessive amount of slippage is created at a driving wheel, thus facilitating the vehicle in providing excellent stability and driving force.

### e. VSC Coordination Control

In order to bring the effectiveness of the VSC system control into full play, the throttle valve opening angle is controlled by effecting a coordination control with the skid control ECU.

### f. Cruise Control

An ECM with an integrated cruise control ECU directly actuates the throttle valve for operation of the cruise control.



4) Fail-safe of Accelerator Pedal Position Sensor

- The accelerator pedal position sensor is comprised of two (main, sub) sensor circuits. If a malfunction occurs in either one of the sensor circuits, the ECM detects the abnormal signal voltage difference between these two sensor circuits and switches to the limp mode. In the limp mode, the remaining circuit is used to calculate the accelerator pedal depressed angle, in order to operate the vehicle under the limp mode control.

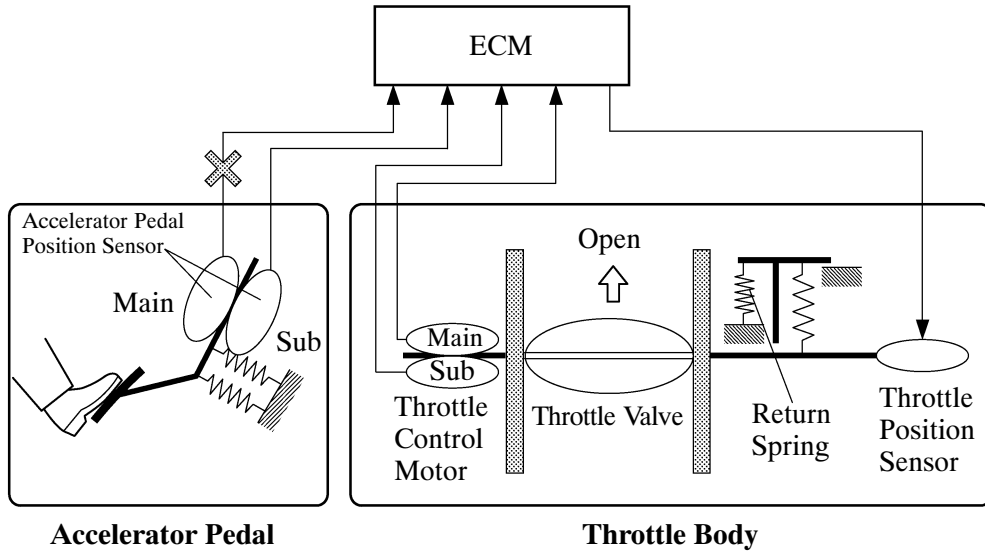

199EG45

- If both circuits have malfunctions, the ECM detects the abnormal signal voltage from these two sensor circuits and stops the throttle control. At this time, the vehicle can be driven within its idling range.

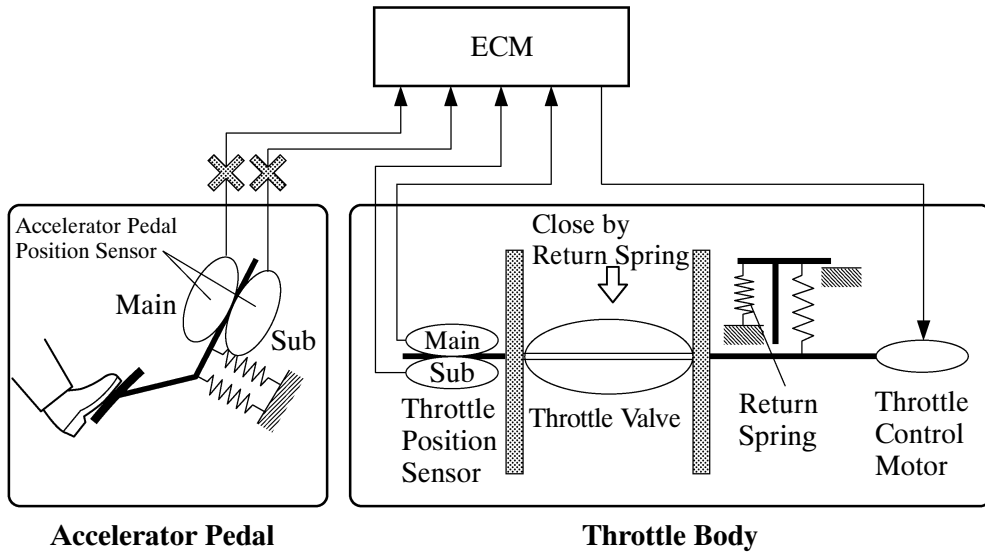

199EG46

### 5) Fail-safe of Throttle Position Sensor

- The throttle position sensor is comprised of two (main, sub) sensor circuits. If a malfunction occurs in either one or both of the sensor circuits, the ECM detects the abnormal signal voltage difference between these two sensor circuits, cuts off the current to the throttle control motor, and switches to the limp mode. Then, the force of the return spring causes the throttle valve to return and stay at the prescribed opening angle. At this time, the vehicle can be driven in the limp mode while the engine output is regulated through the control of the fuel injection (intermittent fuel-cut) and ignition timing in accordance with the accelerator opening.
- The same control as above is effected if the ECM detects a malfunction in the throttle control motor system.

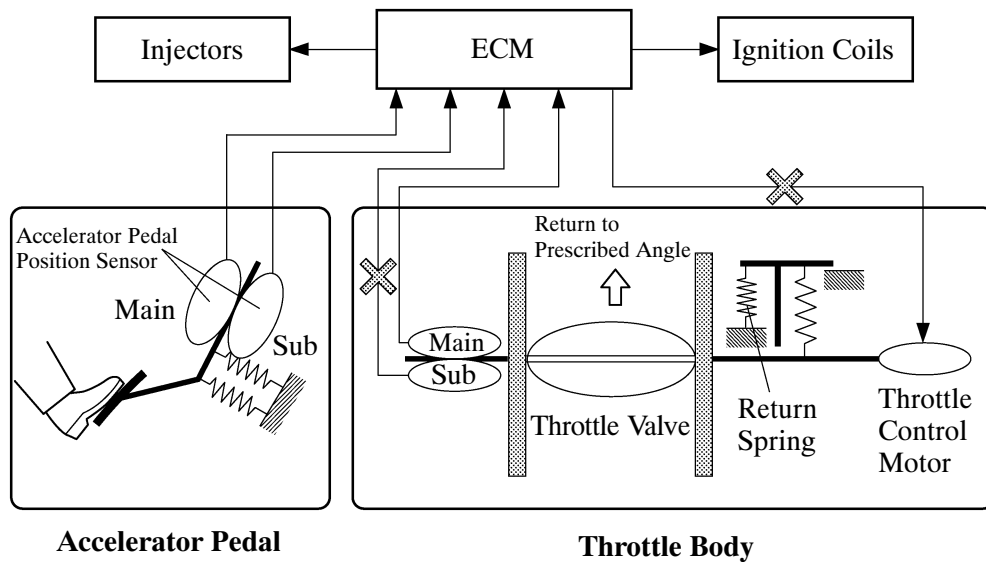

199EG47

## Dual VVT-i (Variable Valve Timing-intelligent) System

### 1) General

- The Dual VVT-i system is designed to control the intake and exhaust camshafts within a range of  $50^\circ$  and  $40^\circ$  respectively (of Crankshaft Angle) to provide valve timing optimally suited to the engine condition. This improves torque in all the speed ranges as well as increasing fuel economy, and reducing exhaust emissions.

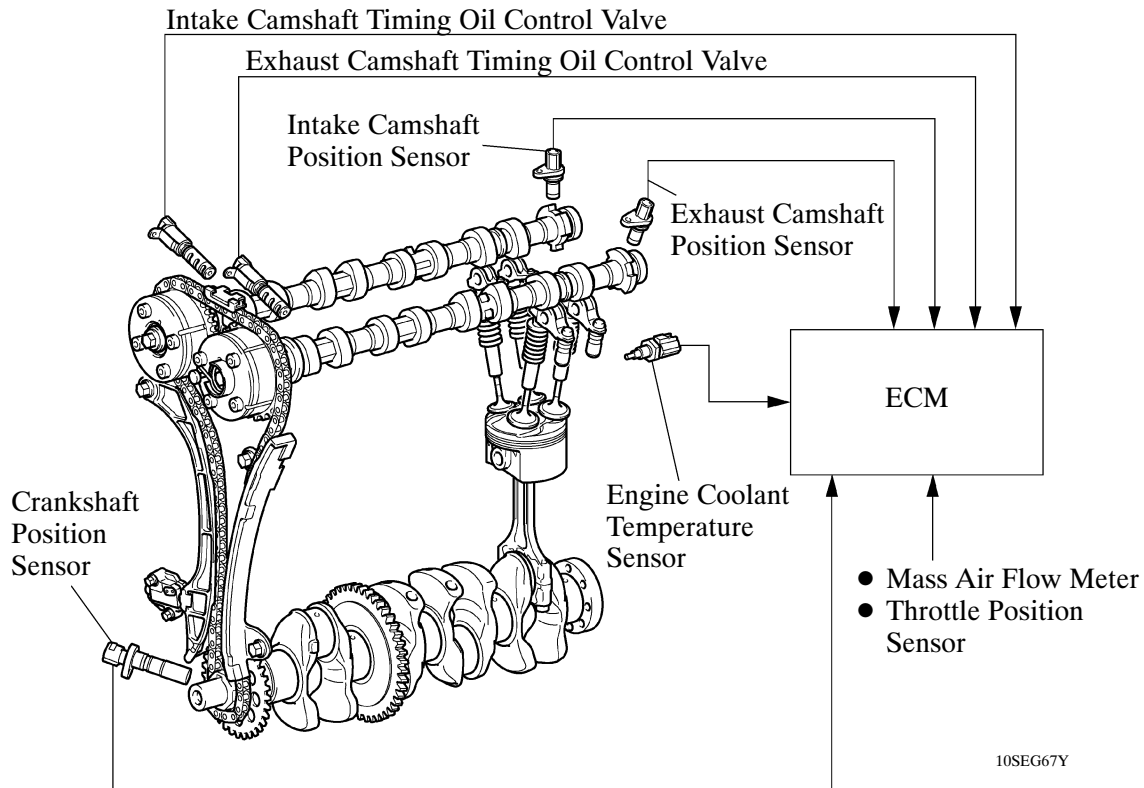

- Using the engine speed, intake air mass, throttle position and engine coolant temperature, the ECM can calculate optimal valve timing for each driving condition and controls the camshaft timing oil control valve. In addition, the ECM uses signals from the camshaft position sensor and the crankshaft position sensor to detect the actual valve timing, thus providing feedback control to achieve the target valve timing.

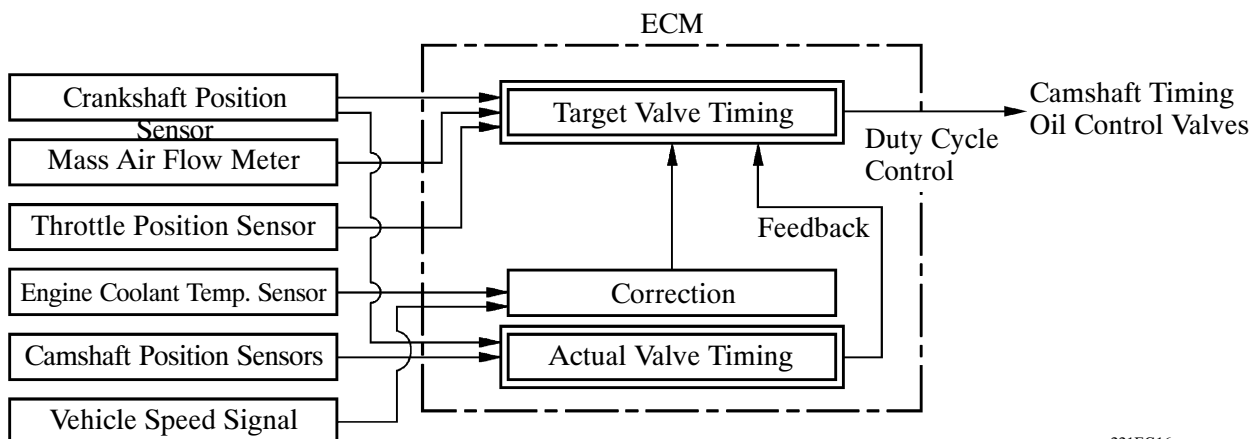

2) Effectiveness of the Dual VVT-i System

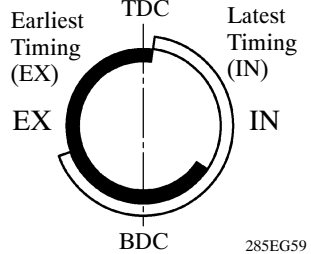
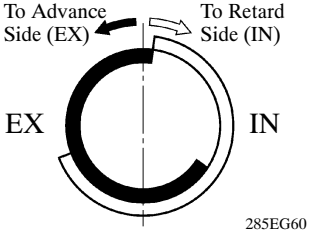
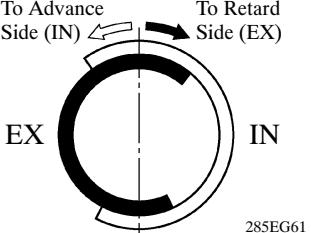
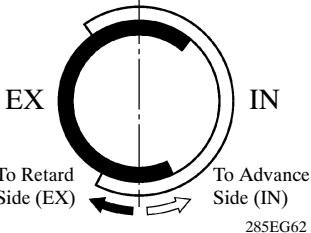
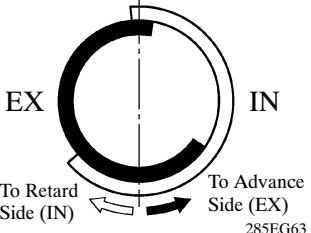
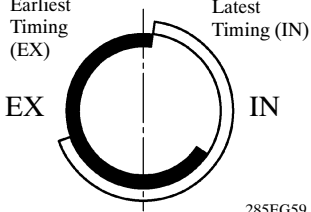
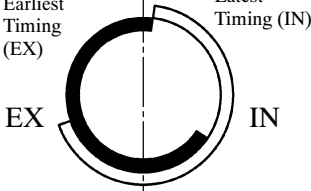
Operation State	Objective	Effect
During Idling	 <p>Eliminating overlap to reduce blow back to the intake side</p> <p>285EG59</p>	<ul style="list-style-type: none"> <li>● Stabilized idling speed</li> <li>● Better fuel economy</li> </ul>
At Light Load	 <p>Eliminating overlap to reduce blow back to the intake side</p> <p>285EG60</p>	Ensured engine stability
At Medium Load	 <p>Increasing overlap to increase internal EGR to reduce pumping loss</p> <p>285EG61</p>	<ul style="list-style-type: none"> <li>● Better fuel economy</li> <li>● Improved emission control</li> </ul>
In Low to Medium Speed Range with Heavy Load	 <p>Advancing the intake valve close timing for volumetric efficiency improvement</p> <p>285EG62</p>	Improved torque in low to medium speed range
In High Speed Range with Heavy Load	 <p>Retarding the intake valve close timing for volumetric efficiency improvement</p> <p>285EG63</p>	Improved output
At Low Temperatures	 <p>Eliminating overlap to reduce blow back to the intake side leads to the lean burning condition, and stabilizes the idling speed at fast idle</p> <p>285EG59</p>	<ul style="list-style-type: none"> <li>● Stabilized fast idle speed</li> <li>● Better fuel economy</li> </ul>
<ul style="list-style-type: none"> <li>● Upon Starting</li> <li>● Stopping the Engine</li> </ul>	 <p>Eliminating overlap to minimize blow back to the intake side</p> <p>285EG59</p>	Improved startability

### 3) Construction

#### a. VVT-i Controller

- Each controller consists of a housing driven by the timing chain and a vane coupled with the intake or exhaust camshaft.
- Both the intake and exhaust sides have a four-blade vane.
- The oil pressure sent from the advanced or retarded side path at the intake and exhaust camshafts causes rotation in the VVT-i controller vane circumferential direction to vary the intake and exhaust valve timing continuously.
- When the engine is stopped, a lock pin locks the intake camshaft at the most retarded end and the exhaust camshaft at the most advanced end, to ensure that the engine starts properly.
- An advance assist spring is provided on the exhaust side VVT-i controller. This spring applies torque in the advance direction when the engine is stopped, thus ensuring the engagement of the lock pin.

#### ► Intake Side VVT-i Controller ◀

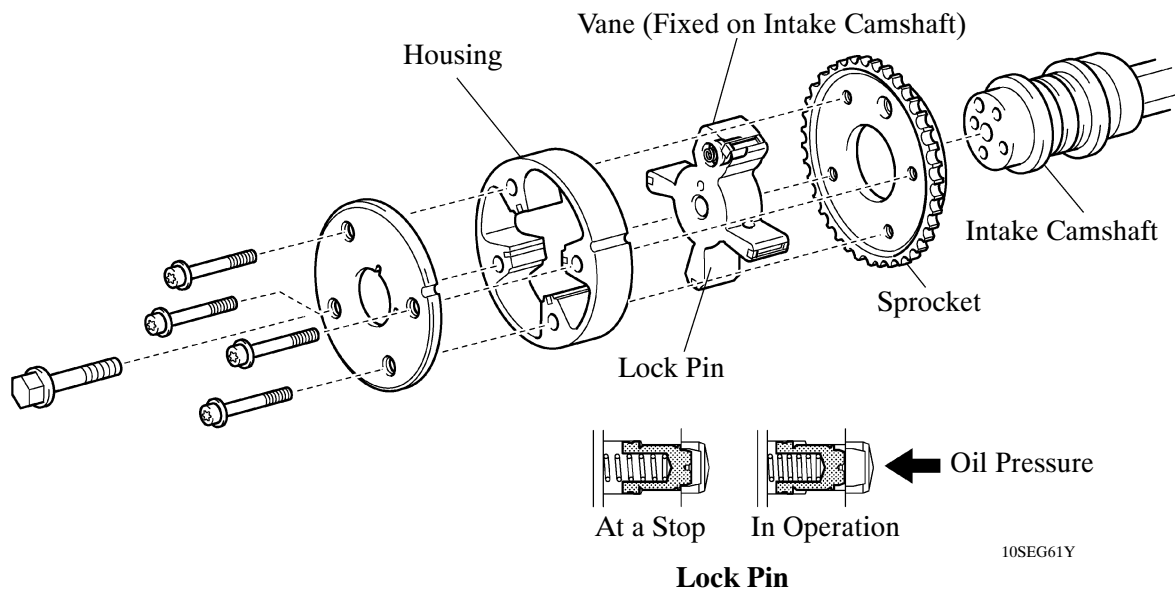

#### ► Exhaust Side VVT-i Controller ◀

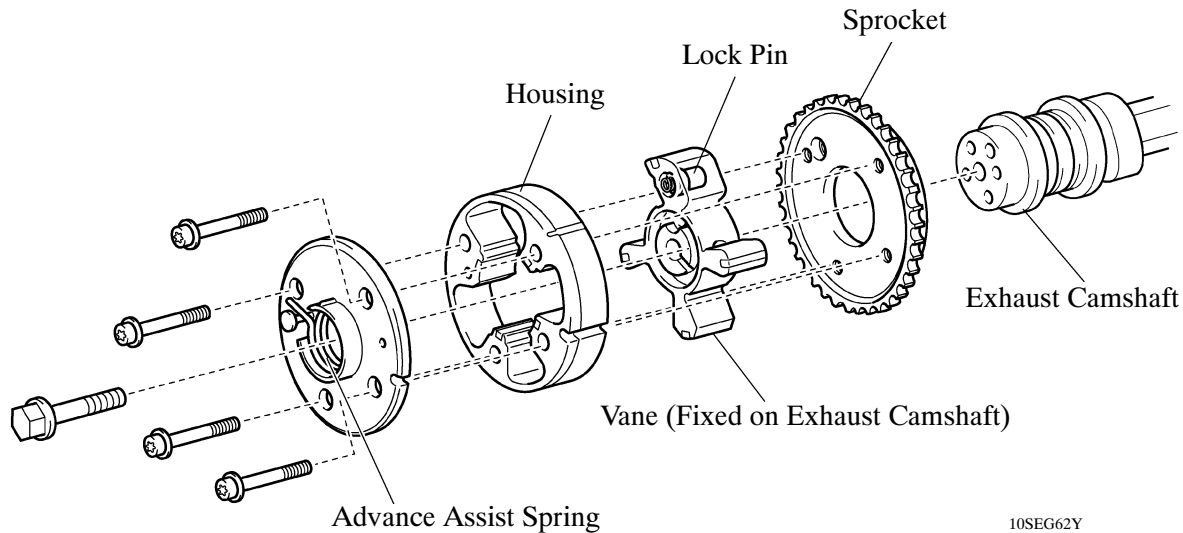

**b. Camshaft Timing Oil Control Valve**

This camshaft timing oil control valve controls the spool valve using duty cycle control from the ECM. This allows hydraulic pressure to be applied to the VVT-i controller advanced or retarded side. When the engine is stopped, the camshaft timing oil control valve is in the most retarded position.

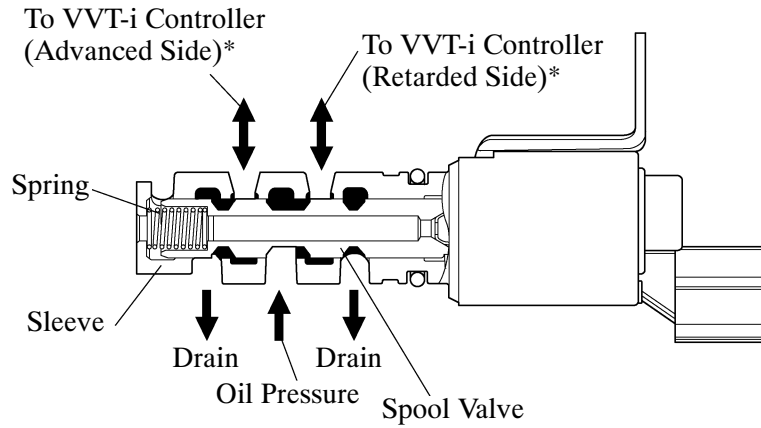

04FEG180Y

\*: On the exhaust side oil control valve, the advance and retard sides are reversed.

## 4) Operation

### a. Advance

When the camshaft timing oil control valve is positioned as illustrated below by the advance signals from the ECM, the resultant oil pressure is applied to the timing advance side vane chamber to rotate the camshaft in the timing advance direction.

#### ► Intake Side ◀

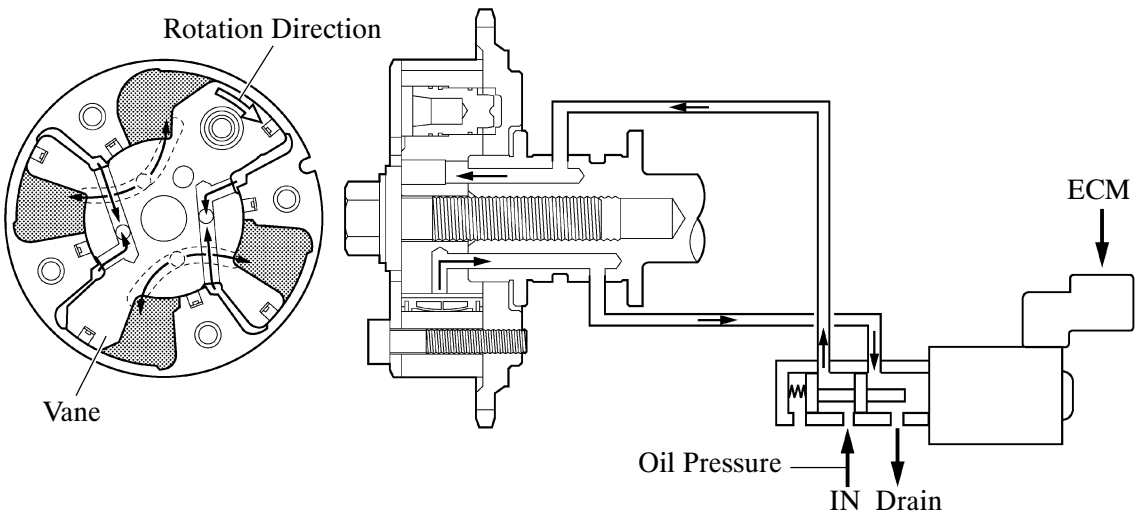

10SEG25Y

#### ► Exhaust Side ◀

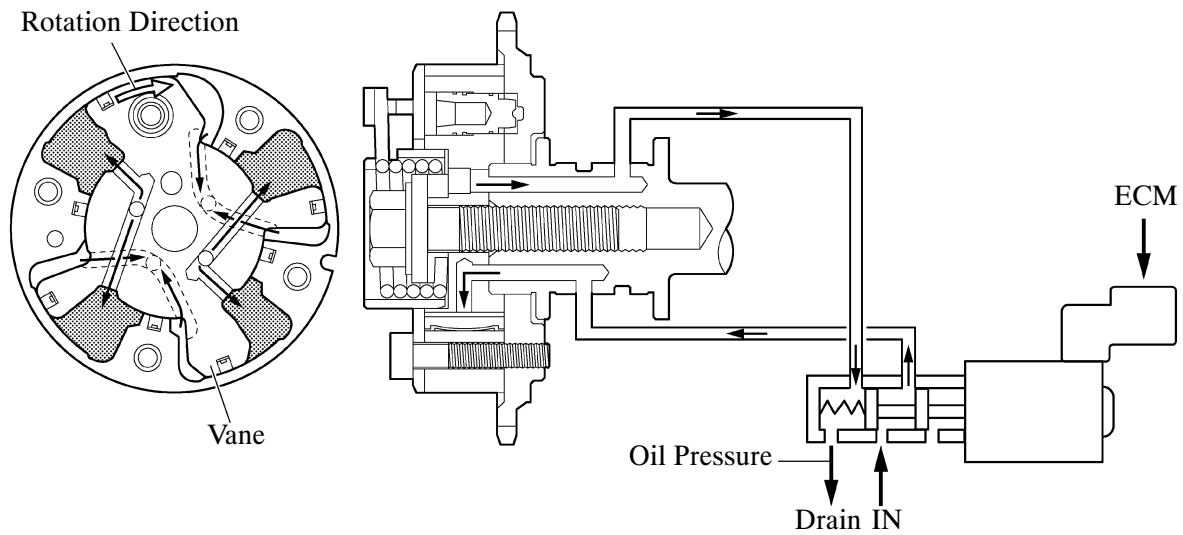

10SEG27Y

**b. Retard**

When the camshaft timing oil control valve is positioned as illustrated below by the retard signals from the ECM, the resultant oil pressure is applied to the timing retard side vane chamber to rotate the camshaft in the timing retard direction.

► Intake Side ◀

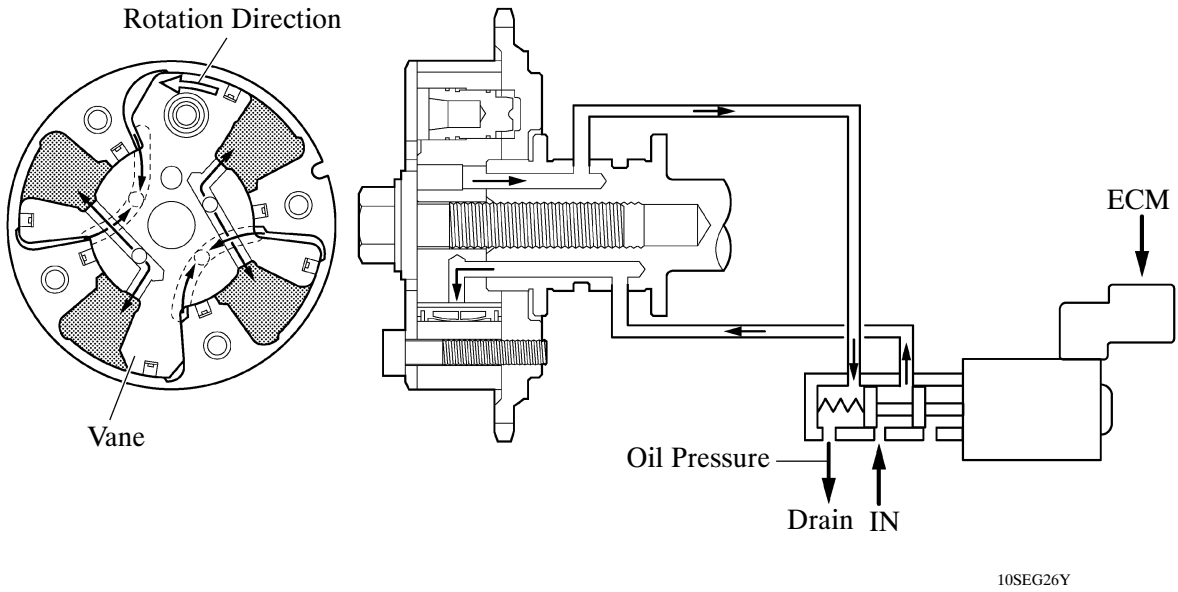

► Exhaust Side ◀

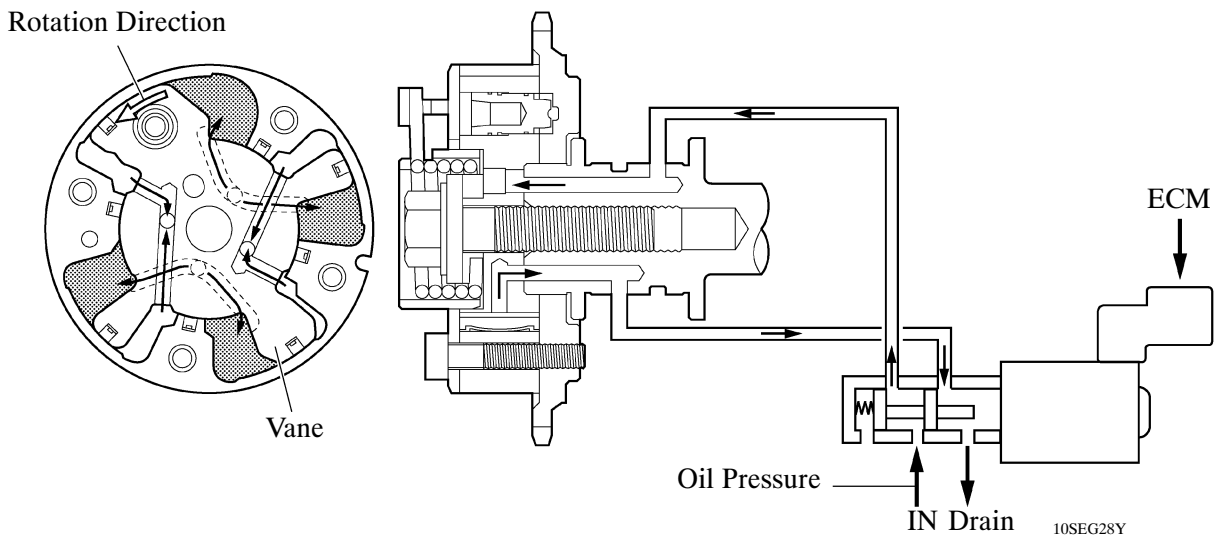

**c. Hold**

After reaching the target timing, the valve timing is held by keeping the camshaft timing oil control valve in the neutral position unless the traveling state changes.

This adjusts the valve timing at the desired target position and prevents the engine oil from running out when it is unnecessary.



## ACIS (Acoustic Control Induction System)

### 1) General

The ACIS is implemented by using a bulkhead to divide the intake manifold into 2 stages, with an intake air control valve in the bulkhead being opened and closed to vary the effective length of the intake manifold in accordance with the engine speed and throttle valve opening angle. This increases the power output in all ranges from low to high speed.

#### ► System Diagram ◀

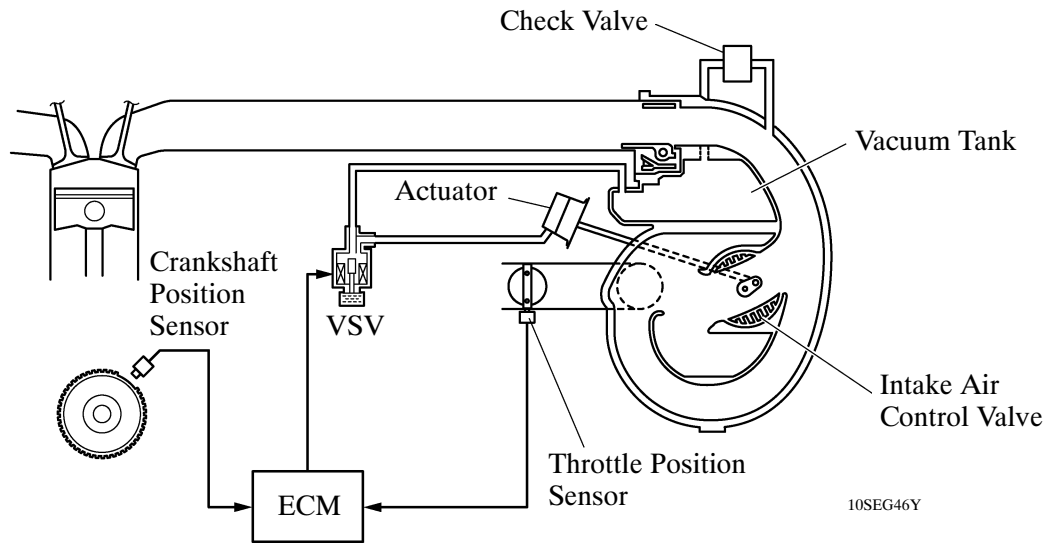

## 2) Construction

### a. Intake Air Control Valve

The intake air control valve is integrated in the intake manifold. It opens and closes to change the effective length of the intake manifold in two stages.

### b. Actuator

The actuator opens and closes the intake air control valve by the vacuum pressure controlled by the VSV.

### c. VSV (Vacuum Switching Valve)

The VSV controls the vacuum applied to the actuator by way of the signal (ACIS) output by the ECM.

### d. Vacuum Tank

The vacuum tank is integrated in the intake manifold. Equipped with a check valve, the vacuum tank stores the vacuum applied to the actuator in order to keep the intake air control valve fully closed even during low-vacuum conditions.

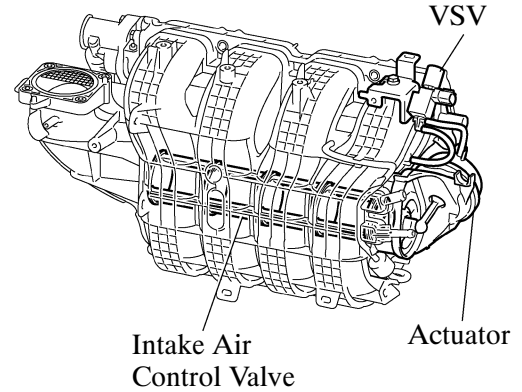

10SEG70Y

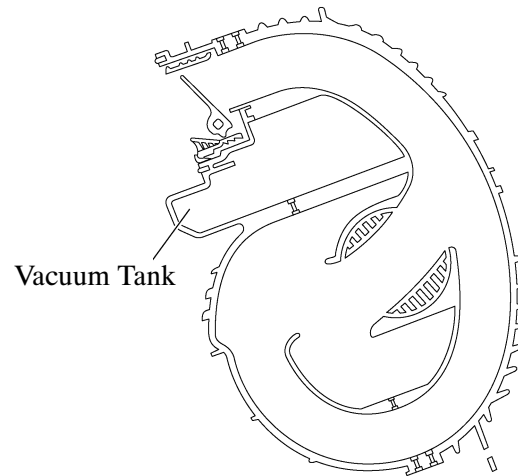

**Intake Manifold Cross Section**

10SEG40Y

3) Operation

a. When the Intake Control Valve Closes (VSV ON)

The ECM activates the VSV to match the longer pulsation cycle so that the negative pressure acts on the diaphragm chamber of the actuator. This closes the control valve. As a result, the effective length of the intake manifold is lengthened and the intake efficiency in the medium speed range is improved due to the dynamic effect of the intake air, thereby increasing the power output.

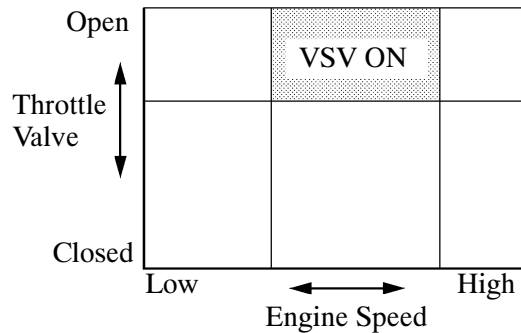
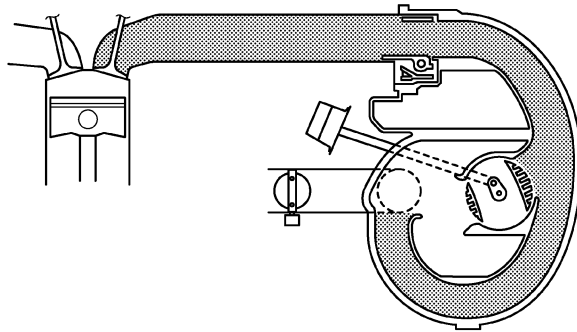

: Effective intake manifold length

10SEG47Y

b. When the Intake Control Valve Opens (VSV OFF)

The ECM deactivates the VSV to match the shorter pulsation cycle so that atmospheric air is led into the diaphragm chamber of the actuator and opens the control valve. When the control valve is open, the effective length of the intake air chamber is shortened and peak intake efficiency is shifted to the low-to-high engine speed range, thus providing greater output at low-to-high engine speeds.

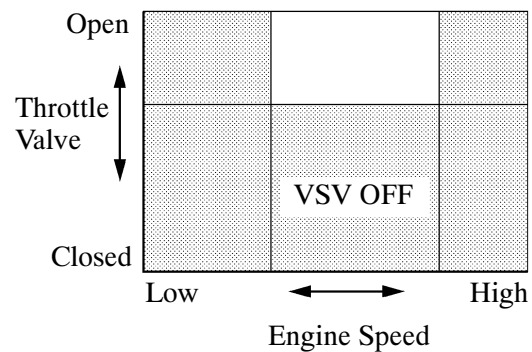
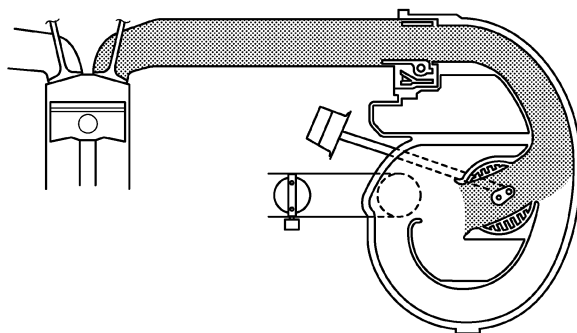

: Effective intake manifold length

10SEG48Y

## Tumble Control System

### 1) General

In the tumble control system, the tumble control valve remains fully closed during cold start and cold running conditions, in order to create a strong tumble current in the combustion chamber. In addition, this system optimally controls the ignition timing and the fuel injection volume in accordance with the opening and closing of the valve. As a result, it improves combustion while the engine is running cold.

#### ► System Diagram ◀

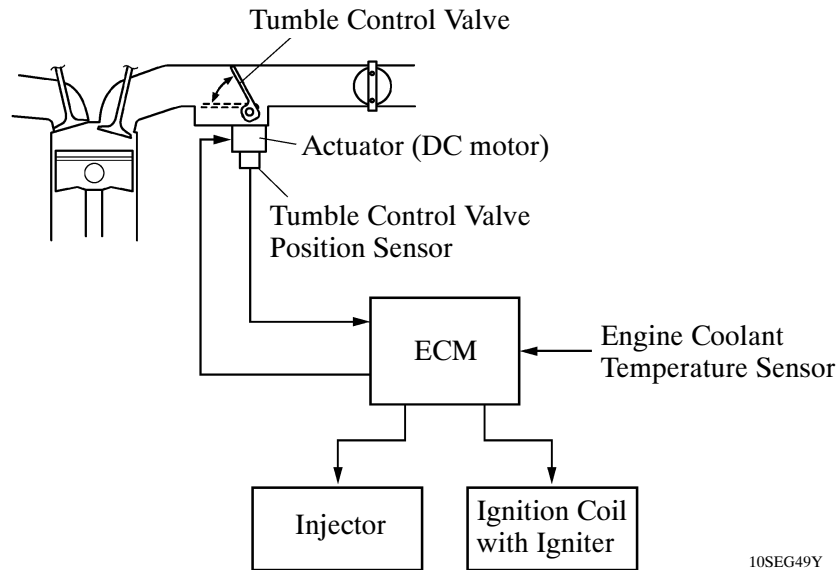

### 2) Construction

#### a. Tumble Control Valve

The tumble control valve is provided in the intake manifold. This valve closes in order to create a tumble current in the combustion chamber.

#### b. Actuator

A DC motor type actuator is provided in the intake manifold. Based on the signals provided by the ECM, the actuator opens and closes the tumble control valve.

#### c. Tumble Control Valve Position Sensor

For details of the tumble control valve position sensor, see page 64.

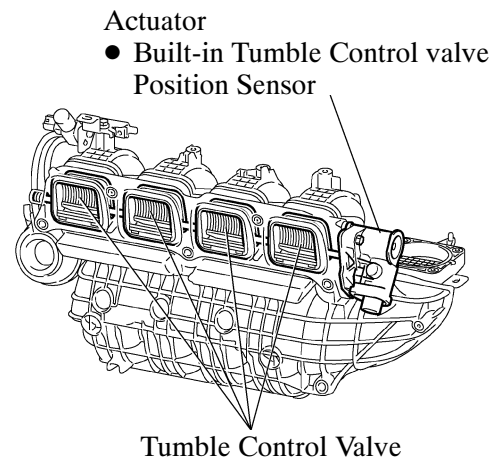

### 3) Operation

#### a. Engine Running Cold

To improve combustion, the ECM operates the actuator to fully close the tumble control valve, in order to create a strong tumble current in the combustion chamber. This enables the engine to operate at a lean air-fuel ratio immediately after a cold start.

Based on the signals from the various sensors, the ECM retards the ignition timing in order to reduce the amount of unburned gas and promote the warming up of the TWC. In addition, the ECM optimizes the fuel injection volume.

The vacuum pressure created downstream of the valve promotes the atomization of the fuel and prevents the fuel from adhering to the ports.

These measures help reduce exhaust gas emissions while the engine is running cold.

#### b. Engine Warmed Up

The ECM operates the actuator to fully open the tumble control valve. When the valve is fully open, the passage has minimal intake resistance in order to improve engine performance.