

Rear Clutch COMPONENTS

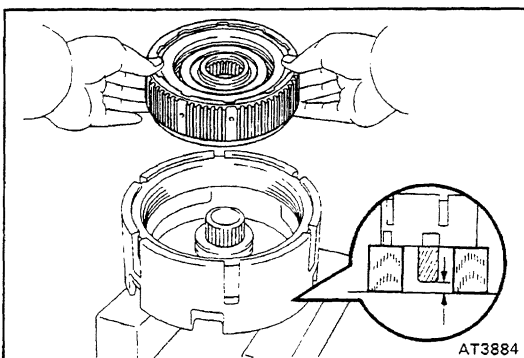
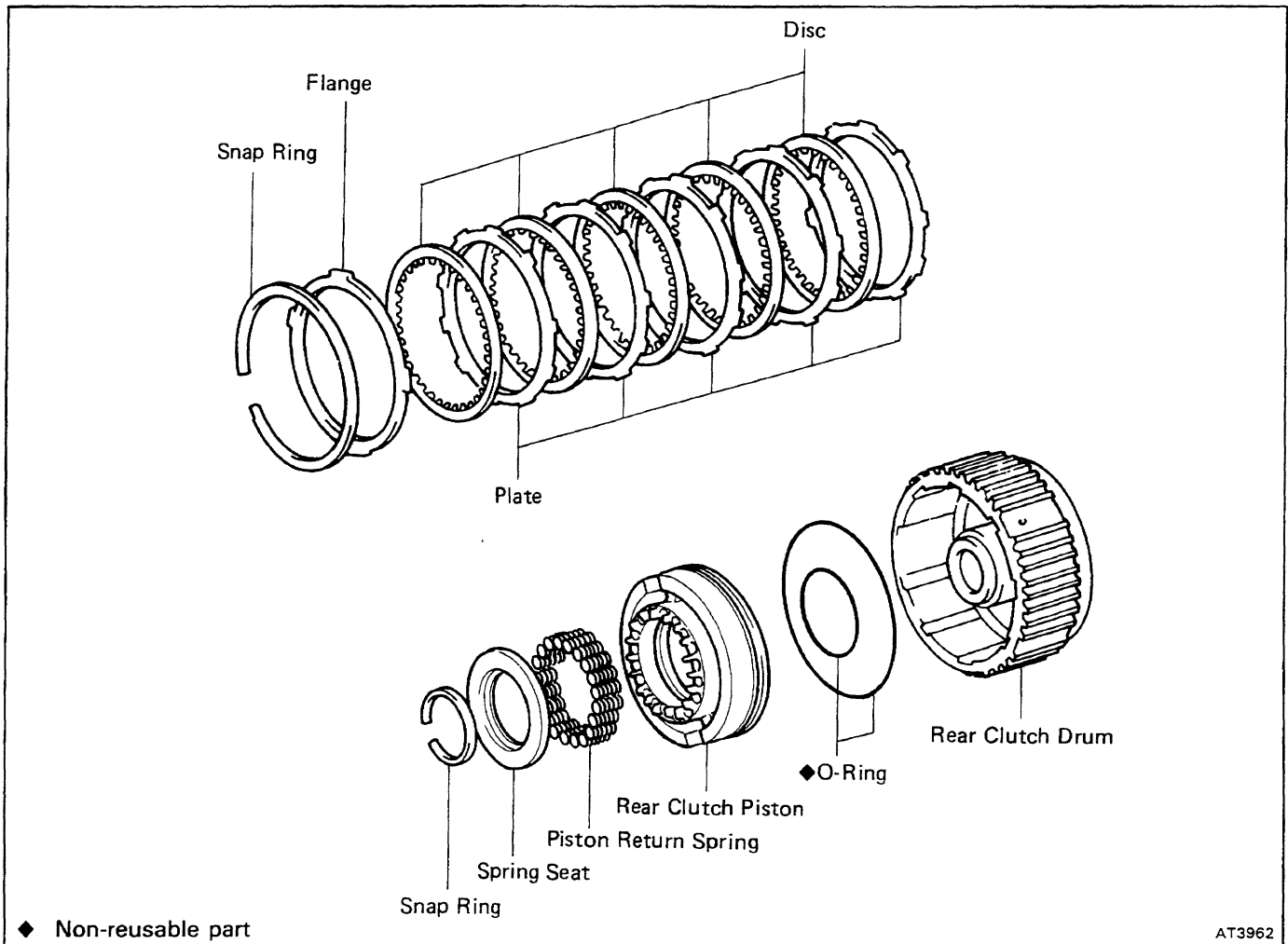

DISASSEMBLY OF REAR CLUTCH

1. CHECK PISTON STROKE OF REAR CLUTCH

(a) Place the center support assembly on wooden blocks.
HINT: Provide clearance so that the sun gear does not touch the rear clutch drum.

(b) Place the rear clutch assembly into the center support assembly.

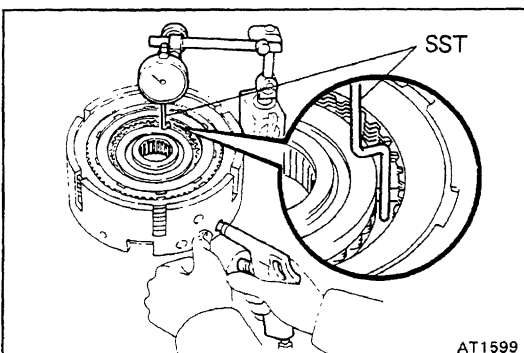

(c) Using SST and a dial indicator, measure the piston stroke by applying and releasing the compressed air (4 - 8 kg/crn², 57 - 114 psi or 392 - 785 kPa) as shown. SST 09350-36010 (09350-06110)

Piston stroke: 1.70 - 1.90 mm (0.0669 - 0.0748 in.)

If the piston stroke is greater than specified, inspect the discs.

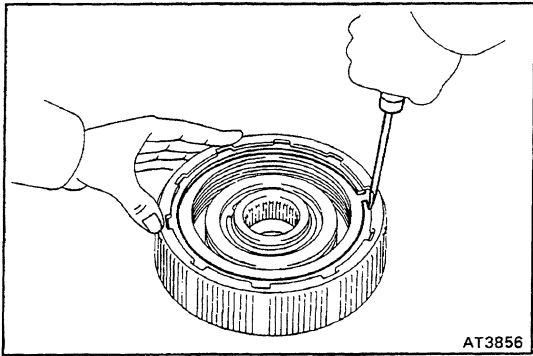

2. REMOVE FLANGE, DISCS AND PLATES

(a) Using a screwdriver, remove the snap ring.

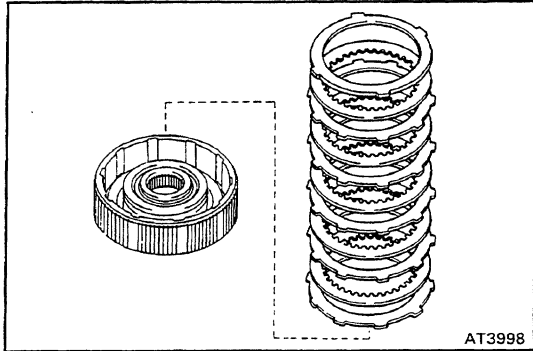

(b) Remove the flange, five discs and five plates.

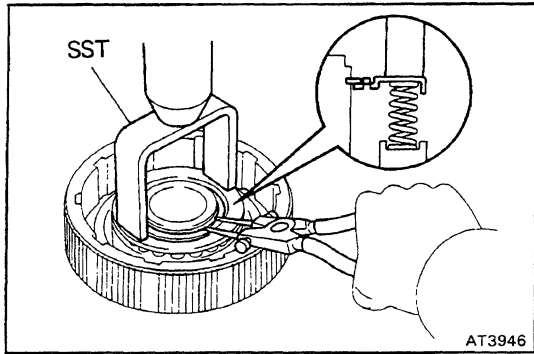

3. REMOVE PISTON RETURN SPRINGS

(a) Place SST on the spring seat, and compress the return spring with a shop press.

SST 09350-36010 (09350-06010)

(b) Using snap ring pliers, remove the snap ring.

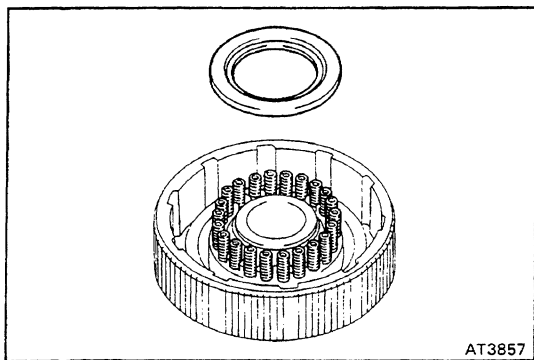

(c) Remove the spring seat and twenty-two return springs.

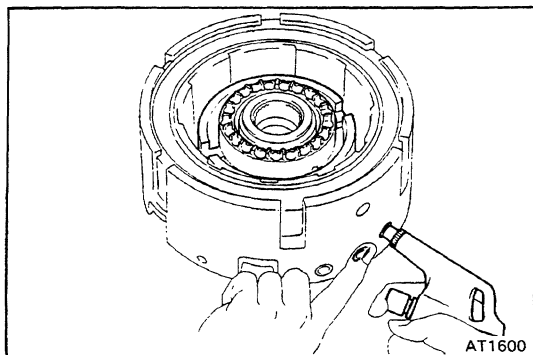

4. REMOVE REAR CLUTCH PISTON

(a) Place the center support assembly on wooden blocks.

(See step (a) on page [AT-84](#))

(b) Place the clutch drum onto the center support assembly.

(c) Hold the piston with hand, apply compressed air into the oil hole of the center support to remove the clutch piston.

(d) Remove the two O-rings from the clutch piston.

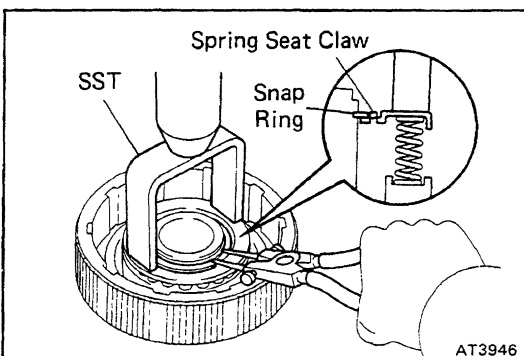
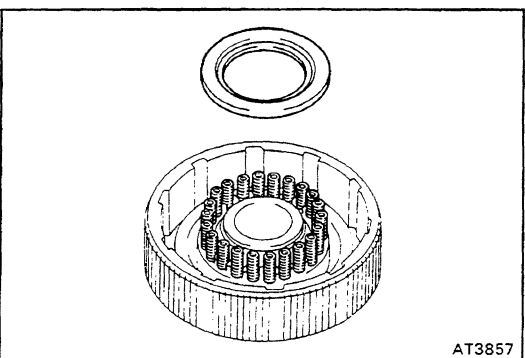
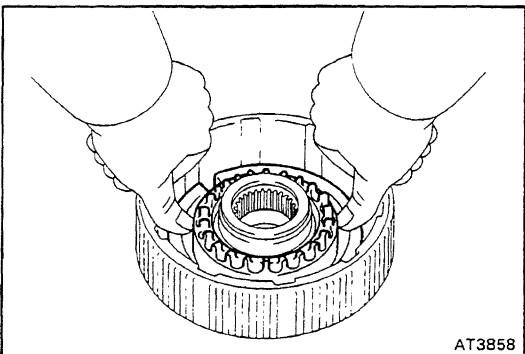
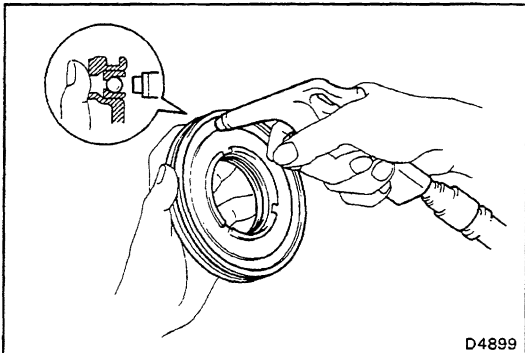
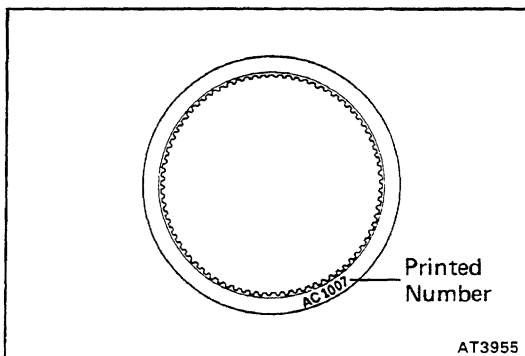

INSPECTION OF REAR CLUTCH

1. INSPECT DISCS, PLATES AND FLANGE

Check to see if the sliding surface of the disc, plate and flange are worn or burnt. If necessary, replace them.

HINT:

- If the lining of the disc is peeling off or discolored, or even if parts of the printed numbers are defaced, replace all discs.
- Before assembling new discs, soak them in ATF for at least two hours.

2. INSPECT REAR CLUTCH PISTON

- Check that check ball is free by shaking the piston.
- Check that the valve does not leak by applying low-pressure compressed air.

ASSEMBLY OF REAR CLUTCH

1. INSTALL REAR CLUTCH PISTON

- Coat new O-rings with ATF, and install them on the clutch drum.
- Push in the clutch piston into the clutch drum with both hands.

NOTICE: Be careful not to damage the O-rings.

2. INSTALL PISTON RETURN SPRINGS

- Place the twenty-two return springs and spring seat on the clutch piston.

- Place SST on the spring seat, and compress the return springs with a shop press.

SST 09350-36010 (09350-06010)

- Using snap ring pliers, install the snap ring.

HINT: Be sure the end gap of the snap ring is not aligned with the spring retainer claw.

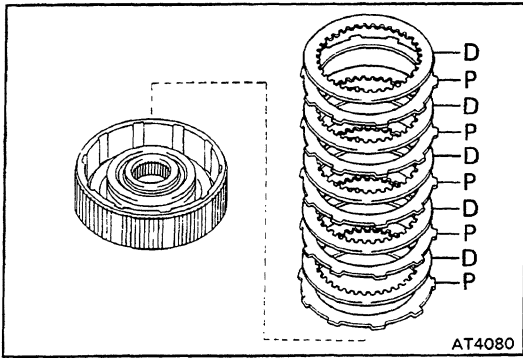

3. INSTALL PLATES, DISCS AND FLANGE

(a) Install the five plates and five discs in order:

P = Plate D = Disc

P-D -P-D-P-D -P-D -P-D

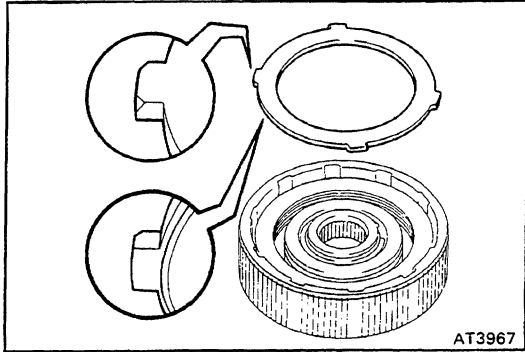

(b) Install the flange, facing the rounded edge upward.
 HINT: If the flange is step-edged, install the flange with the step-edge, facing downward.

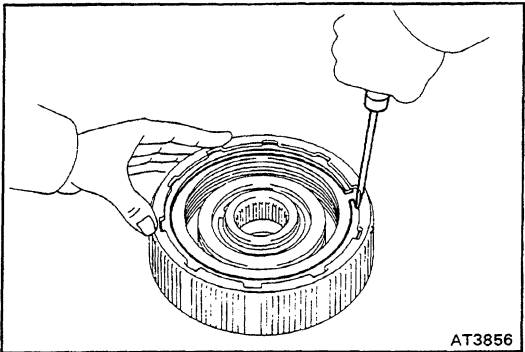

(c) Using a screwdriver, install the snap ring.
 HINT: Be sure the end gap of the snap ring is not aligned with the cut out portion of the rear clutch drum.

4. CHECK PISTON STROKE OF REAR CLUTCH

(a) Place the center support assembly on wooden blocks.
 HINT: Provide clearance so that the sun gear does not touch the rear clutch drum.

(b) Place the rear clutch assembly onto the center support assembly.

(c) Using SST and a dial indicator, measure the piston stroke by applying and releasing the compressed air

(4 - 8 kg/cm², 57 - 114 psi or 392 - 785 kPa) as shown.

SST 09350-36010 (09350-06110)

Piston stroke: 1.70 - 1.90 mm (0.0669 - 0.0748 in.)

If the piston stroke is less than specified, parts may have been assembled incorrectly, check and reassemble again.

If the piston stroke is not as specified, select another flange.

HINT: There are four different thickness for flange.
 mm (in.)

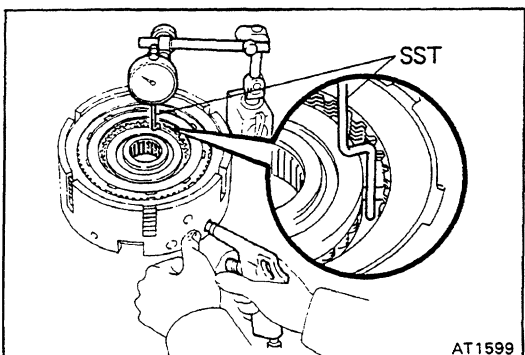
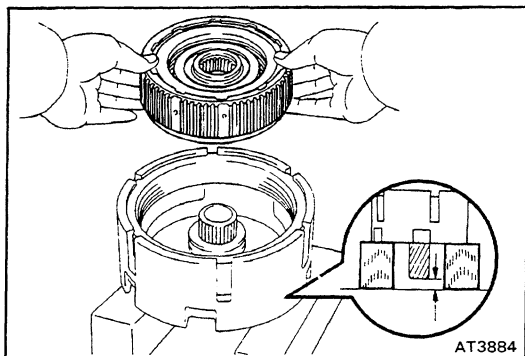

No.	Thickness	No.	Thickness
None	5.0 (0.197)	2	5.4 (0.213)
1	5.2 (0.205)	3	5.6 (0.220)