

VALVE BODY ASSEMBLY

REMOVAL

CAUTION:

When working with FIPG material, you must observe the following guidelines.

- Using a razor blade and gasket scraper, remove all the old FIPG material from the gasket surfaces.
- Thoroughly clean all components to remove all loose material.
- Clean both sealing surfaces with a non-residue solvent.
- Apply FIPG in an approximately 1 mm (0.04 in.) wide bead along the sealing surface.
- Parts must be assembled within 10 minutes of application. Otherwise, the FIPG material must be removed and reapplied.

1. DISCONNECT CABLE FROM NEGATIVE BATTERY TERMINAL

2. DRAIN AUTOMATIC TRANSMISSION FLUID

- (a) Remove the drain plug, gasket and drain ATF.
- (b) Install a new gasket and drain plug.
Torque: 28 N*m (285 kgf*cm, 21 ft.*lbf)

3. REMOVE AUTOMATIC TRANSMISSION OIL PAN SUB-ASSEMBLY

NOTICE:

Some fluid will remain in the oil pan.

- (a) Remove the 20 bolts, gasket and oil pan sub-assembly.

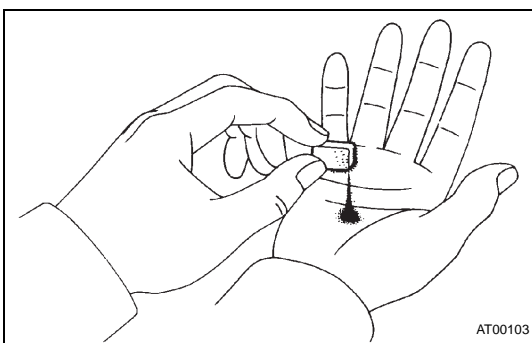
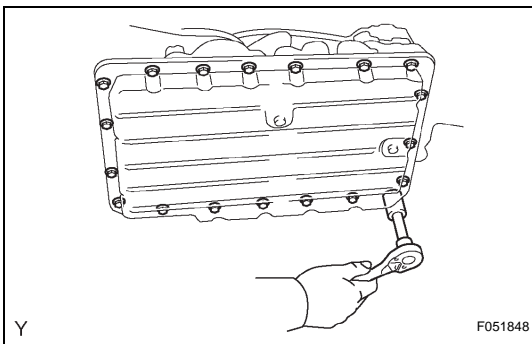

- (b) Examine the particles in the pan.

- (1) Remove the magnets and use them to collect steel particles. Carefully inspect the foreign matter and particles in the pan and on the magnets to anticipate the type of wear you will find in the transmission.

Steel (magnetic) ... bearing, gear and clutch plate wear

Brass (non-magnetic) ... bushing wear

AT

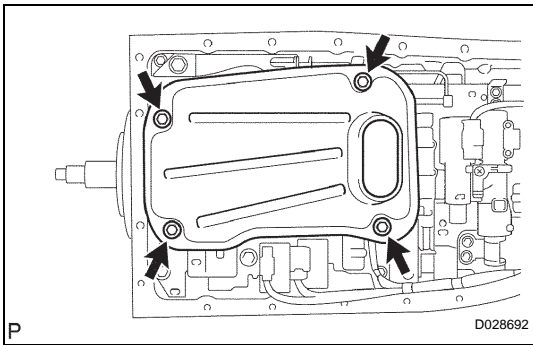

4. **REMOVE VALVE BODY OIL STRAINER ASSEMBLY**
 - (a) Remove the 4 bolts, oil strainer and O-ring.

NOTICE:
Be careful as some fluid will come out of the oil strainer.
5. **SEPARATE TRANSMISSION WIRE** (See page [AT-143](#))

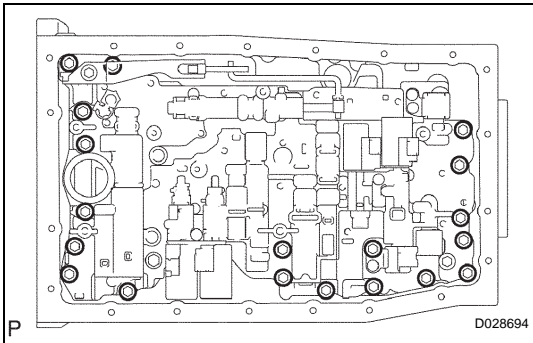

6. **REMOVE TRANSMISSION VALVE BODY ASSEMBLY**
 - (a) Remove the 19 bolts and valve body.
 - (b) Remove the 3 drum seal gaskets.

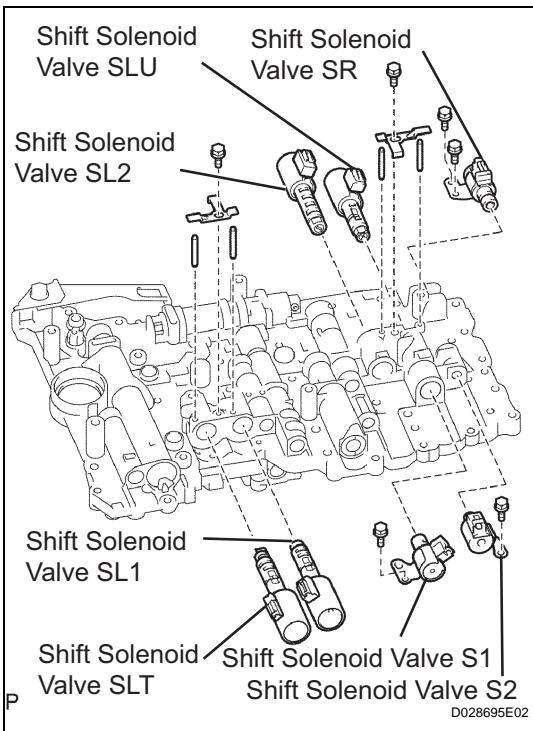

- (c) Remove the bolt, lock plate, pin and shift solenoid valves SLT and SL1.
- (d) Remove the bolt, lock plate, pin and shift solenoid valves SLU and SL2.
- (e) Remove the 2 bolts and shift solenoid valve SR.
- (f) Remove the bolt and shift solenoid valve S1.
- (g) Remove the bolt and shift solenoid valve S2.