

REMOVAL

1. **DISCHARGE FUEL SYSTEM PRESSURE**
(See page [FU-1](#))
2. **DISCONNECT CABLE FROM NEGATIVE BATTERY TERMINAL**
3. **REMOVE NO.1 FUEL TANK PROTECTOR SUB-ASSEMBLY (OFF ROAD PACKAGE)**
4. **DISCONNECT FUEL TANK MAIN TUBE AND FUEL TANK RETURN TUBE** (See page [FU-30](#))
5. **REMOVE FUEL TANK ASSEMBLY** (See page [FU-30](#))
6. **REMOVE FUEL TANK MAIN TUBE AND FUEL TANK RETURN TUBE** (See page [FU-32](#))
7. **REMOVE FUEL SUCTION WITH PUMP & GAUGE TUBE ASSEMBLY** (See page [FU-33](#))

8. DRAIN FUEL

DISASSEMBLY

1. **REMOVE FUEL SENDER GAUGE ASSEMBLY**
 - (a) Disconnect the connector.

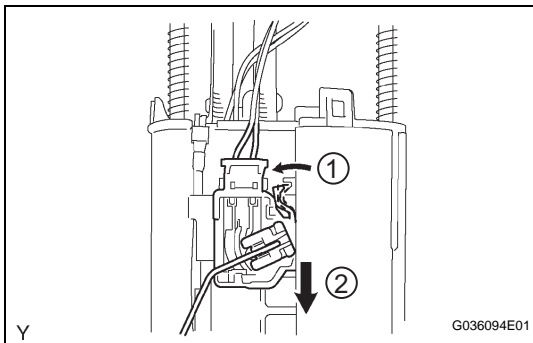
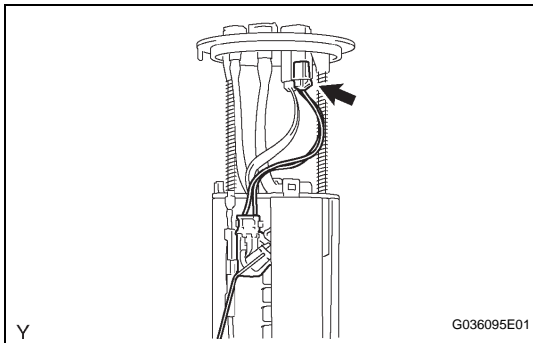

- (b) Disengage the claw fitting and remove the sender gauge by sliding it in the direction as shown in the illustration.

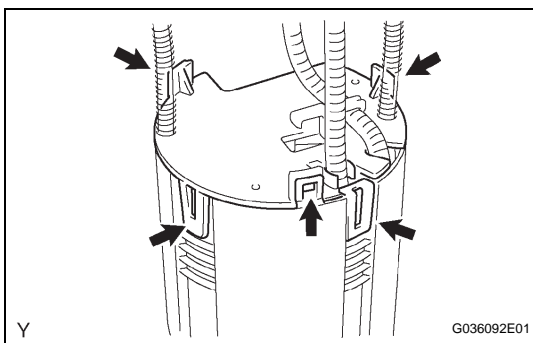

2. **REMOVE NO. 1 FUEL SUB-TANK**

- (a) Disengage the 5 claw fittings and remove the fuel pump tank.

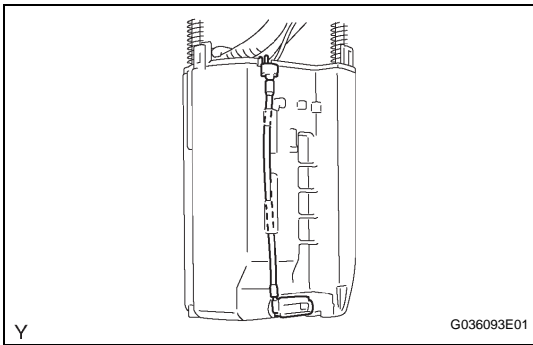

(b) Separate the connector and disengage the clamp.

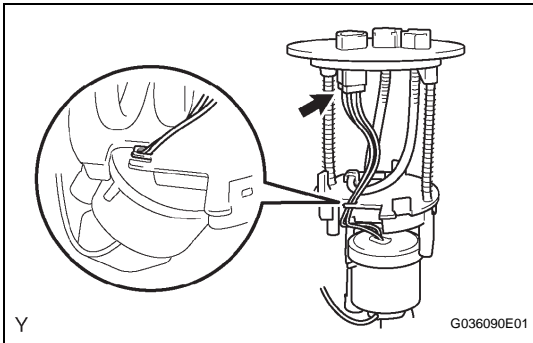

3. REMOVE FUEL PUMP ASSEMBLY

(a) Disengage the clamp, then disconnect the connector.

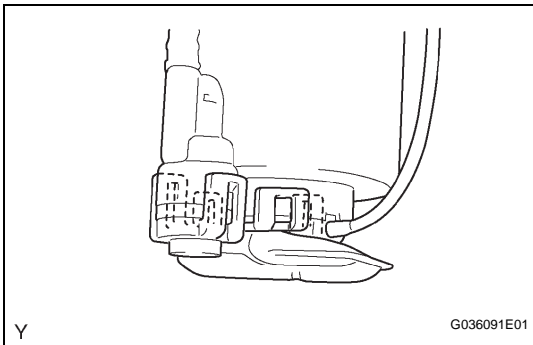

(b) Disengage the 5 claw fittings and separate the fuel pump from the fuel pump case.

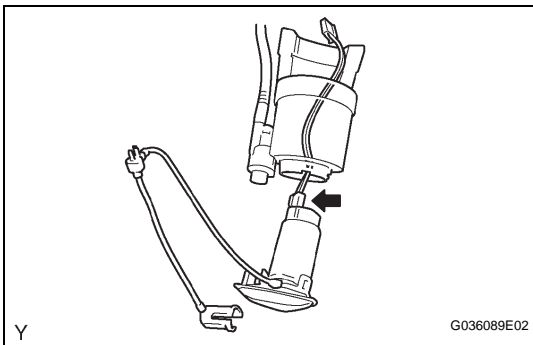

(c) Disconnect the connector from the fuel pump.

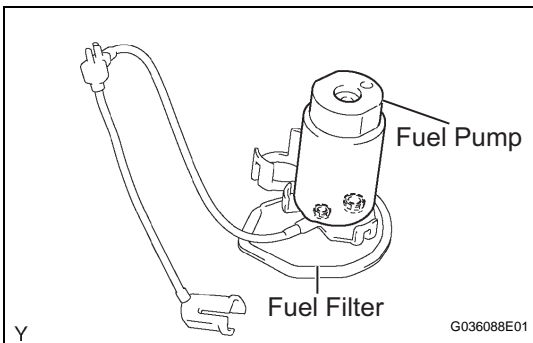

4. REMOVE FUEL PUMP FILTER

(a) Remove the fuel filter from the fuel pump.

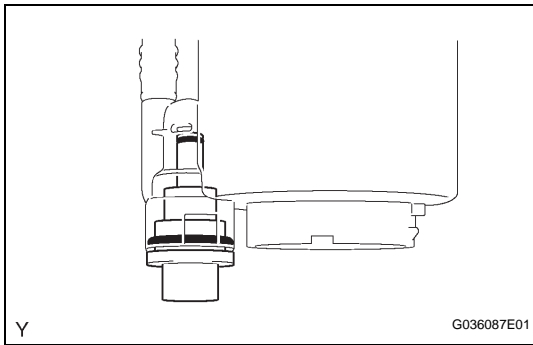

5. REMOVE FUEL PRESSURE REGULATOR ASSEMBLY

- (a) Remove the fuel pressure regulator and the 2 O-rings.

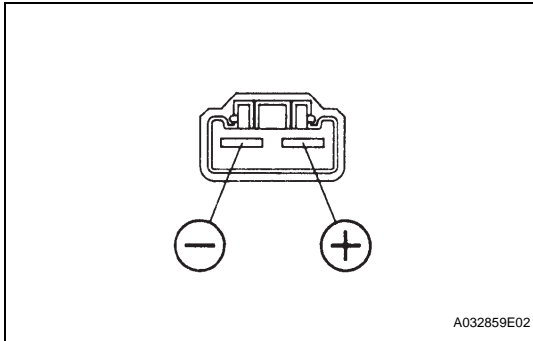

INSPECTION

1. INSPECT FUEL PUMP ASSEMBLY

- (a) Check the resistance.
 - (1) Using an ohmmeter, measure the resistance between the terminals.

Resistance:

0.2 to 3.0 Ω at 20°C (68°F)

- (b) Check the operation.
 - (1) Apply battery voltage to both terminals. Check that the pump operates.

NOTICE:

- **These tests must be performed quickly (within 10 seconds) to prevent damage to the pump.**
- **Keep the fuel pump as far away from the battery as possible.**
- **Always do the switching at the battery side.**